



ROTEX®
Torsionally flexible coupling

Made for Motion



Table of contents



ROTEX®	
Torsionally flexible coupling	17
Description of coupling	19
Coupling selection	20
Selection of standard IEC motors	22
Displacements and installation	23
Spider types - Materials, physics, properties	24
Technical data	25
Cylindrical bores and spline bores	26
Inch bores and taper bores	27
Shaft coupling - casted materials	28
Shaft coupling - material steel	29
Shaft coupling with taper clamping bush	30
Clamping ring hubs	31
Clamping hubs	32
Flange programme types AFN and BFN	33
Drop-out center design coupling type A-H	34
Flange programme types CF, CFN, DF and DFN	35
Double cardanic type ZS-DKM-H	36
Double cardanic type DKM	37
Intermediate shaft programme type ZR	38
Type BTAN with brake drum/type SBAN with disk brake	39
Type AFN-SB special with disk brake	40
Type SD (shiftable at standstill)	41
Type FNN and FNN with fan	42
Further types with clamping sets	43
Further types with torque limiter	44
Hub designs	45
Weights and mass moment of inertia	46

Description of coupling

ROTEX® - couplings are characterized by small dimensions, low weight and low mass moments of inertia yet transmit high torques. Running quality and service life of the coupling are improved by accurate all-over machining.

Their application is ideal for transmitting torque while damping torsional vibrations and absorbing shocks produced by the uneven operation of certain prime movers.

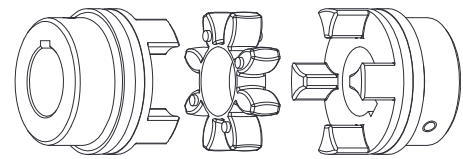

General description

ROTEX® - couplings are torsionally flexible and designed for positive torque transmission. They are fail-safe. Operational vibrations and shocks are efficiently dampened and reduced. The two congruent coupling halves with concave claws on the inside are periphally offset in relation to one another by half a pitch. In addition, they are designed in such a way as to enable an involute spider to be located between them.

The teeth of the spider are crowned to avoid edge pressure if the shafts are misaligned. ROTEX® couplings are capable of compensating for axial, radial and angular displacements of the shafts to be connected.

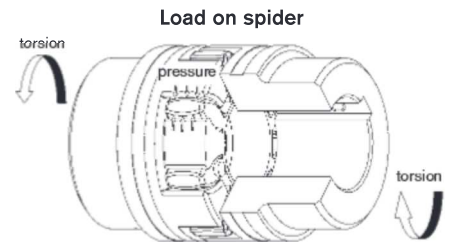

Performance

In contrast to other flexible couplings, the intermediate members of which are subject to bending stress and are therefore prone to earlier wear, the flexible teeth of ROTEX® couplings are subject to pressure only. This gives the additional advantage of the individual teeth being able to accept considerably higher loads. The elastomer parts show deformation with load and excessive speeds. Sufficient space for expansion should be ensured (see drawing – deformation with load).

The maximum torsion angle with ROTEX® couplings of any size amounts to 5°. They can be fitted both horizontally and vertically.

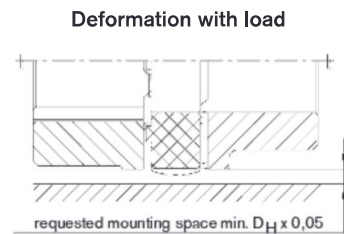

Explosion-proof use

ROTEX® couplings are suitable for power transmission in drives in hazardous areas. The couplings are certified and confirmed according to EC standard 94/9/EC (ATEX 95) as units of category 2G/2D and thus suitable for the use in hazardous areas of zone 1, 2, 21 and 22. Please read through our information included in the respective Type Examination Certificate and the operating and mounting instructions at www.ktr.com.



Spiders

An operating temperature range of - 40 °C to + 90 °C ensures perfect operation. Transient temperature peaks up to + 120 °C do not cause any damage on the coupling. Continuous improvement of materials has resulted in a standard spider of 92 Shore A which offers various advantages over usual polyurethane materials. For higher torques it is also possible to make use of a spider 95/98 Shore A or 64 Shore D-F.

The spiders are extremely resistant to wear, oil, ozone and ageing. In addition, they are resistant to hydrolysis (ideal for tropical climates).

The high internal damping protects the drive against dynamic overload.

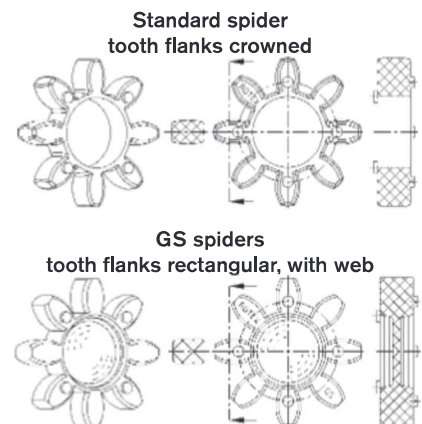

Comparison of loads

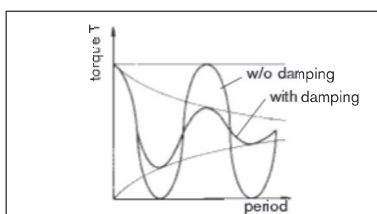

Twisting angle

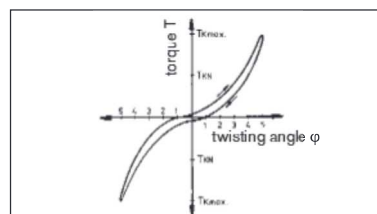

Damping

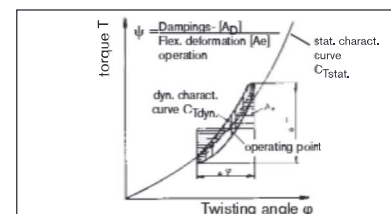

Coupling selection

The ROTEX® coupling is selected in accordance with DIN 740 part 2. The coupling has to be dimensioned in a way that the permissible coupling load is not exceeded in any operating condition. For this purpose the actual loads have to be compared to the permissible parameters of the coupling.

1 Drives without periodical torsional vibrations

e. g. centrifugal pumps, fans, screw compressors, etc.
The coupling is selected taking into account the rated torques T_{KN} and maximum torque $T_{K\ max}$.

1.1 Load produced by rated torque

Taking into consideration the ambient temperature, the permissible rated torque T_{KN} of the coupling has to correspond at least to the rated torque T_N of the machine.

$$T_N \text{ [Nm]} = 9550 \cdot \frac{P \text{ [kW]}}{n \text{ [rpm]}}$$

$$T_{KN} \geq T_N \cdot S_t$$

1.2 Load produced by torque shocks

The permissible maximum torque of the coupling has to correspond at least to the total of peak torque T_S and the rated torque T_N of the machine, taking into account the shock frequency Z and the ambient temperature.

This applies in case if the rated torque T_N of the machine is at the same time subject to shocks.

Knowing the mass distribution, shock direction and shock mode, the peak torque T_S can be calculated.

For drives with A, C.-motors with high masses on the load side we would recommend to calculate the peak driving torque with the help of our simulation programme.

$$T_{K\ max} \geq T_S \cdot S_z \cdot S_t + T_N \cdot S_t$$

$$\text{Drive-sided shock } T_S = T_{AS} \cdot M_A \cdot S_A$$

$$\text{Load-sided shock } T_S = T_{LS} \cdot M_L \cdot S_L$$

$$M_A = \frac{J_L}{J_A + J_L} \quad M_L = \frac{J_A}{J_A + J_L}$$

2. Drives with periodical torsional vibrations.

For drives subject to high torsional vibrations, e. g. diesel engines, piston compressors, piston pumps, generators, etc., it is necessary to perform a torsional vibration calculation to ensure a safe operation. If requested, we perform the torsional vibration calculation and the coupling selection in our company. For necessary details please see KTR standard 20004.

2.1 Load produced by rated torque

Taking into account the ambient temperature, the permissible rated torque T_{KN} of the coupling has to correspond at least to the rated torque T_N of the machine.

$$T_{KN} \geq T_N \cdot S_t$$

2.2 Passing through the resonance range

Taking into account the temperature, the peak torque T_S arising when the resonance range is run through must not exceed the maximum torque $T_{K\ max}$ of the coupling.

$$T_{K\ max} \geq T_S \cdot S_t$$

2.3 Load produced by vibratory torque shocks

Taking into account the ambient temperature, the permissible vibratory torque T_{KW} of the coupling must not be exceeded by the highest periodical vibratory torque T_W with operating speed.

$$T_{KW} \geq T_W \cdot S_t$$

$$P_{KW} \geq P_W$$

For higher operating frequencies $f > 10$, the heat produced by damping in the elastomer part is considered as damping power P_W .

The permissible damping power P_{KW} of the coupling depends on the ambient temperature and must not be exceeded by the damping power produced.

Description	Symbol	Definition or explanation
Rated torque of coupling	T_{KN}	Torque that can continuously be transmitted over the entire permissible speed range
Maximum torque of coupling	$T_{K\ max}$	Torque that can be transmitted as dynamic load $\geq 10^2$ times or 5×10^4 as vibratory load, respectively, during the entire operating life of the coupling
Vibratory torque of coupling	T_{KW}	Torque amplitude of the permissible periodical torque fluctuation with a frequency of 10 Hz and a basic load of T_{KN} or dynamic load up to T_{KN} , respectively
Damping power of coupling	P_{KW}	Permissible damping power with an ambient temperature of + 30 °C.
Rated torque of machine	T_N	Stationary rated torque on the coupling
Rated torque of driving side	T_{AN}	Rated torque of machine, calculated from rated power and rated speed
Rated torque of load side	T_{LN}	Maximum figure of the load torque calculated from power and speed
Peak torque of machine	T_S	Peak torque on the coupling
Peak torque on the driving side	T_{AS}	Peak torque with torque shock on the driving side, e. g. breakdown torque of the electric motor

Description	Symbol	Definition or explanation
Peak torque of load side	T_{LS}	Peak torque with torque shock on load side, e. g. braking
Vibratory torque of machine	T_W	Amplitude of the vibratory torque effective on the coupling
Damping power of the machine	P_W	Damping power which is effective on the coupling due to the load produced by the vibratory torque
Moment of inertia of driving side	J_A	Total of moments of inertia existing on the driving or load side referring to the coupling speed
Moment of inertia of load side	J_L	
Rotational inertia coefficient of driving side	M_A	Factor taking into account the mass distribution with shocks and vibrations produced on the driving or load side
Rotational inertia coefficient of load side	M_L	
		$M_A = \frac{J_L}{(J_A + J_L)} \quad M_L = \frac{J_A}{(J_A + J_L)}$

Coupling selection

Service factor S_t for temperature				
	-30 °C +30 °C	+40 °C	+60 °C	+80 °C
S_t	1,0	1,2	1,4	1,8

Service factor S_z for starting frequency				
starting frequency/h	100	200	400	800
S_z	1,0	1,2	1,4	1,6

Service factor S_A/S_L for shocks	
	S_A/S_L
gentle shocks	1,5
average shocks	1,8
heavy shocks	2,5

Permissible load on feather key of the coupling hub

The shaft-hub-connection has to be verified by the customer. Permissible surface pressure according to DIN 6892 (method C).

Cast iron EN-GJL-250 (GG 25)	225 N/mm ²
material nodular iron EN-GJS-400-15 (GGG 40)	225 N/mm ²
material steel S355J2G3 (St 52.3)	250 N/mm ²
for other steel materials $p_{zul} =$	$0,9 \cdot R_e (R_{p0,2})$

Example of calculation of standard IEC motors shown on page 22:

Given: Details of driving side

A. C. motor	type 315 L $\Rightarrow S_A = 1,8$
Motor output	$P = 160 \text{ kW}$
Speed	$n = 1485 \text{ rpm}$
Moment of inertia driven side	$J_A = 2,9 \text{ kgm}^2$
Start-up frequency	$z = 6^{1/3} \Rightarrow S_z = 1,0$
Ambient temperature	$= +60 \text{ °C} \Rightarrow S_t = 1,4$

Given: Details of load side

Screw compressor	
Rated torque of load side	$T_{LN} = 930 \text{ Nm}$
Moment of inertia of load side	$J_L = 6,8 \text{ kgm}^2$

Calculation

● Rated driving torque

$$T_{AN} [\text{Nm}] = 9550 \frac{P_{AN} [\text{kW}]}{n_{AN} [\text{rpm}]}$$

$$T_{AN} = 9550 \cdot \frac{160 \text{ kW}}{1485 \text{ rpm}} = 1029 \text{ Nm}$$

Coupling selection:

● Load produced by rated torque

$$T_{KN} \geq T_{LN} \cdot S_t$$

$$T_{KN} \geq 930 \text{ Nm} \cdot 1,4 = 1302 \text{ Nm}$$

Selected: ROTEX® Size 90 - spider 92 Shore A with:

$$T_{KN} = 2400 \text{ Nm}$$

$$T_{K \max} = 4800 \text{ Nm}$$

● Load produced by torque shocks

$$T_{K \max} \geq T_S \cdot S_z \cdot S_t$$

$$\text{Drive-sided shock } T_S = T_{AS} \cdot M_A \cdot S_A$$

$$M_A = \frac{J_L}{(J_A + J_L)} = \frac{6,8 \text{ kgm}^2}{(2,9 \text{ kgm}^2 + 6,8 \text{ kgm}^2)} = 0,7$$

● Driving torque

$$T_{AS} = 2,0 \cdot T_{AN}$$

$$= 2,0 \cdot 1029 \text{ Nm} = 2058 \text{ Nm}$$

$$T_S = 2058 \text{ Nm} \cdot 0,7 \cdot 1,8 = 2593,1 \text{ Nm}$$

$$T_{K \max} \geq 2593,1 \text{ Nm} \cdot 1 \cdot 1,4 = 3630,3 \text{ Nm}$$

$$T_{K \max} \text{ with } 4800 \text{ Nm} \geq 3630,3 \text{ Nm} \quad \checkmark$$

Selection of standard IEC motors

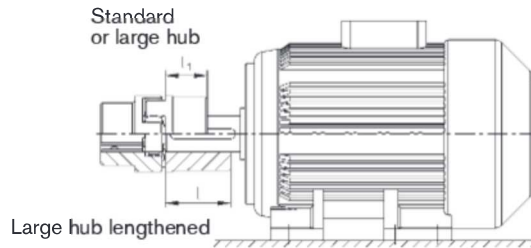

ROTEX® couplings for standard IEC motors, protection IP 54/IP 55 (spider 92 Shore A)													
A. C. motor 50 Hz		Motor output n = 3000 1/min 2-pole		ROTEX® coupling size	Motor output n = 1500 1/min 4-pole		ROTEX® coupling size	Motor output n = 1000 1/min 6-pole		ROTEX® coupling size	Motor output n = 750 1/min 8-pole		ROTEX® coupling size
Size	Shaft end d x l [mm]		Output P [kW]		Torque T [Nm]	Output P [kW]		Torque T [Nm]	Output P [kW]		Torque T [Nm]	Output P [kW]	
	2-pole	4,6,8 pole											
56	9 x 20		0,09	0,32	9 ¹⁾	0,06	0,43	9 ¹⁾	0,037	0,43	9 ¹⁾		
			0,12	0,41		0,09	0,64		0,045	0,52			
63	11 x 23		0,18	0,62	14	0,12	0,88	14	0,06	0,7	14		
			0,25	0,86		0,18	1,3		0,09	1,1			
71	14 x 30		0,37	1,3	14	0,25	1,8	14	0,18	2	14	0,09	1,4
			0,55	1,9		0,37	2,5		0,25	2,8		0,12	1,8
80	19 x 40		0,75	2,5	19	0,55	3,7	19	0,37	3,9	19	0,18	2,5
			1,1	3,7		0,75	5,1		0,55	5,8		0,25	3,5
90S	24 x 50		1,5	5	19	1,1	7,5	19	0,75	8	19	0,37	5,3
90L	24 x 50		2,2	7,4		1,5	10		1,1	12		0,55	7,9
100L	28 x 60		3	9,8	24	2,2	15	24	1,5	15	24	0,75	11
112M	28 x 60		4	13		3	20		1,5	15		1,1	16
132S	38 x 80		5,5	18	28	4	27	28	2,2	22	28	1,5	21
			7,5	25		5,5	36		3	30		2,2	30
132M	38 x 80				28	7,5	49	28	4	40	28	3	40
						7,5	49		5,5	55		3	40
160M	42 x 110		11	36	38	11	72	38	7,5	75	38	4	54
			15	49		15	98		11	109		5,5	74
160L	42 x 110		18,5	60	38	18,5	121	38	11	109	38	7,5	100
180M	48 x 110		22	71		22	144		15	148		11	145
180L	48 x 110				42	22	144	42	15	148	42	11	145
200L	55 x 110		30	97		30	196		18,5	181		15	198
225S	55 x 110		37	120	42	37	240	48	22	215	48	18,5	244
225M	55 x 110	60 x 140	45	145		45	292		30	293		22	290
250M	60 x 140	65 x 140	55	177	55	356	37	361	30	392	65	30	392
280S	75 x 140		75	241	55	75	484	65 ²⁾	45	438	65 ²⁾	37	483
280M			90	289		90	581		55	535		45	587
315S	80 x 170		110	353	55	110	707	75	75	727	75	55	712
315M			132	423		132	849		90	873		75	971
315L	65 x 140		160	513	65	160	1030	90	110	1070	90	90	1170
			200	641		200	1290		132	1280		110	1420
315	85 x 170				75			90	160	1550	90	132	1710
			250	802		250	1600		200	1930		160	2070
355	75 x 140		315	1010	90	315	2020	100	250	2410	100	200	2580
			355	1140		355	2280		315	3040		250	3220
400	80 x 170		400	1280	90	400	2570	110	315	3040	110	250	3220
			500	1600		500	3210		400	3850		315	4060
400	110 x 210		560	1790	125	560	3580	125	450	4330	125	355	4570
			630	2020		630	4030		500	4810		400	5150
450	90 x 170		710	2270	100	710	4540	140	560	5390	140	450	5790
			800	2560		800	5120		630	6060		500	6420
450	120 x 210		900	2880	110	900	5760	160	710	6830	160	560	7190
			1000	3200		1000	6400		800	7690		630	8090

The arrangement of couplings is valid for an ambient temperature of up to + 30 °C. For the selection there is a minimum safety factor of 2 of the max. coupling torque (T_{Kmax}).

A detailed arrangement is possible according to catalogue, page 20 and 21. Drives with periodical torque curves must be selected according to DIN 740 part 2. If requested, KTR will make the selection.

Torque T = nominal torque according to Siemens catalogue M 11 · 1994/95.

¹⁾ For dimensions see ROTEX® GS line

²⁾ Motor hub from steel see page 29

Displacements and installation

Displacements

Axial displacement ΔK_a

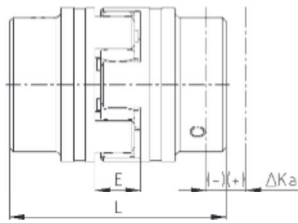

$$L_{max} = L + \Delta K_a$$

Radial displacement ΔK_r

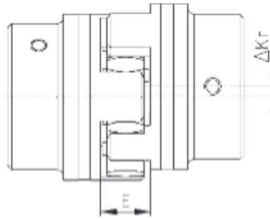

Angular displacement ΔK_w [degrees]

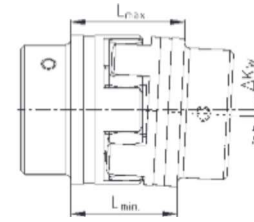

$$\Delta K_w \text{ [mm]} = L_{max} - L_{min}$$

Displacements																	
ROTEX® Size	14	19	24	28	38	42	48	55	65	75	90	100	110	125	140	160	180
Max. axial displacement ΔK_a [mm]	-0,5 +1,0	-0,5 +1,2	-0,5 +1,4	-0,7 +1,5	-0,7 +1,8	-1,0 +2,0	-1,0 +2,1	-1,0 +2,2	-1,0 +2,6	-1,5 +3,0	-1,5 3,4	-1,5 +3,8	-2,0 +4,2	-2,0 +4,6	-2,0 +5,0	-2,5 +5,7	-3,0 +6,4
Max. radial displacement with $n=1500$ rpm ΔK_r [mm]	0,17	0,20	0,22	0,25	0,28	0,32	0,36	0,38	0,42	0,48	0,50	0,52	0,55	0,60	0,62	0,64	0,68
Max. angular displacement with $n=1500$ rpm ΔK_w [degree]	1,2	1,2	0,9	0,9	1,0	1,0	1,1	1,1	1,2	1,2	1,2	1,2	1,3	1,3	1,2	1,2	1,2
ΔK_w [mm]	0,67	0,82	0,85	1,05	1,35	1,70	2,00	2,30	2,70	3,30	4,30	4,80	5,60	6,50	6,60	7,60	9,00

The above-mentioned figures of displacement of flexible ROTEX® couplings are standard values taking into account the load of the coupling up to the rated torque T_{KN} and an operating speed $n = 1500$ rpm along with an ambient temperature of $+ 30^\circ \text{C}$. For different operating conditions please order our data sheet KTR-N 20240 regarding displacements for ROTEX®. The displacement figures may only be used one by one - if they appear simultaneously, they must be limited in proportion. Care should be taken to maintain the distance dimension E accurately in order to allow for axial clearance of the coupling while in operation. In case of an axial shifting the dimension "L" has to be considered as a minimum dimension in order to keep the spider free from pressure on its faces. Detailed mounting instructions are shown on our homepage (www.ktr.com).

Installation

Shaft with keyway (acc. DIN 6885) protruding into the spider $\varnothing d_W$

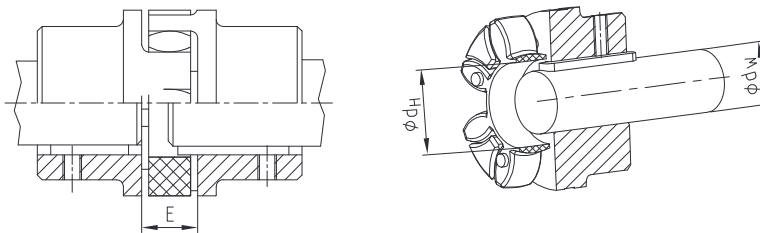

Mounting dimension																	
ROTEX® Size	14	19	24	28	38	42	48	55	65	75	90	100	110	125	140	160	180
Distance dimension E	13	16	18	20	24	26	28	30	35	40	45	50	55	60	65	75	85
Dimension d_H	10	18	27	30	38	46	51	60	68	80	100	113	127	147	165	190	220
Dimension d_W	7	12	20	22	28	36	40	48	55	65	80	95	100	120	135	160	185

Spider types - Materials, physics, properties

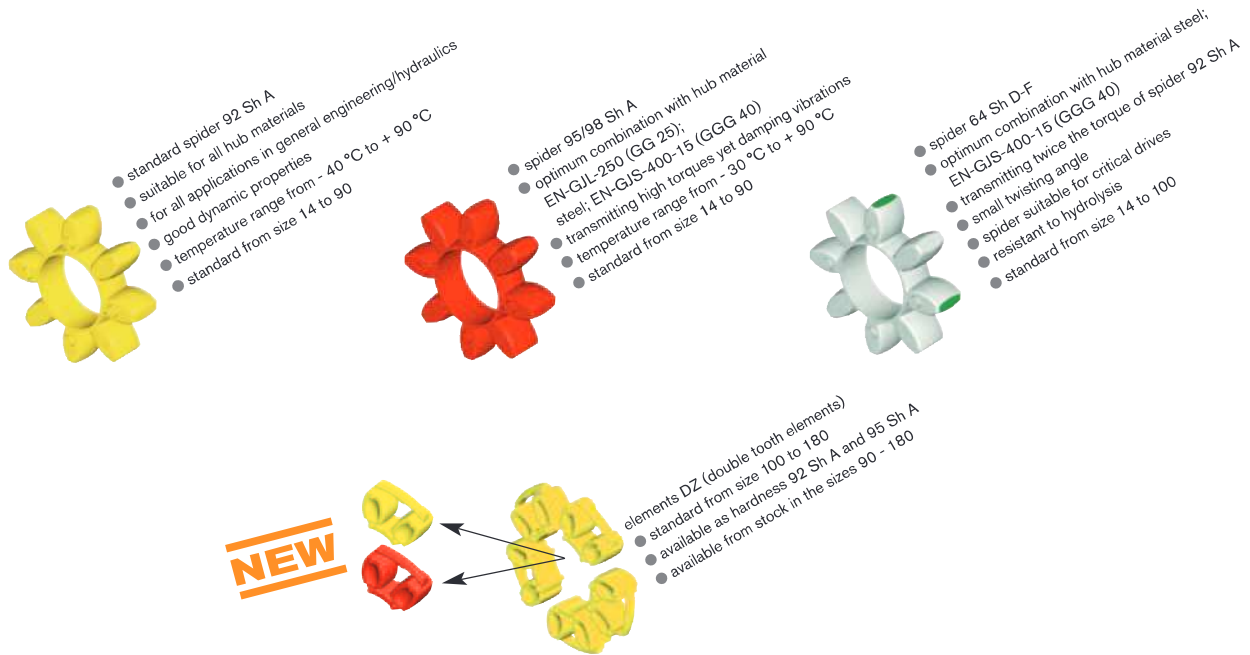

Standard spiders						
Spider type hardness (Shore)	Identification (colour)	Material	Perm. temperature range (°C)		Available for coupling size	Typical applications
			Continuous temperature	Max. temperature short time		
92 Sh A	yellow	polyurethane	- 40 to + 90	- 50 to + 120	size 14 – 180	- for all applications in general engineering and hydraulics - Standard applications with average elasticity
95/98 Sh A	red	polyurethane	- 30 to + 90	- 40 to + 120	size 14 – 180	- good torque transmission with good damping properties
64 Sh D-F ¹⁾	natural white with green tooth flanks	polyurethane	- 30 to + 110	- 30 to + 130	size 14 – 180	- high air moisture, resistant to hydrolysis - displacement of critical speeds

Spiders for special applications on request for:						
Typical applications	Spider type hardness (Shore)	Identification (colour)	Material	Perm. temperature range (°C)		
				Continuous temperature	Max. temperature short time	
For relatively large twisting angles, for drives subject to dangerous torsional vibrations, for shifting critical speeds	80 Sh A	blue	polyurethane	- 50 to + 80	- 60 to + 130	
For high dynamic load, high air moisture/resistant to hydrolysis	94 Sh A-T	blue with yellow tooth flanks	polyurethane	- 50 to + 110	- 60 to + 130	
Drives with higher loads, small twisting angles - torsionally rigid, high ambient temperatures	64 Sh D-H	green	hytel	- 50 to + 110	- 60 to + 150	
Small twisting angles and high torsion spring stiffness, high ambient temperature, good resistance to chemicals ²⁾	polyamide	-	PA	- 20 to + 130 ²⁾	- 30 to + 150 ²⁾	
Small twisting angles and high torsion spring stiffness, very high ambient temperature, good resistance to chemicals, resistant to hydrolysis	PEEK	light grey	PEEK	to + 180 (ATEX release up to a max. +160)	to + 250	

¹⁾ Size 19: 64Sh D-H

²⁾ Different properties depending on compound

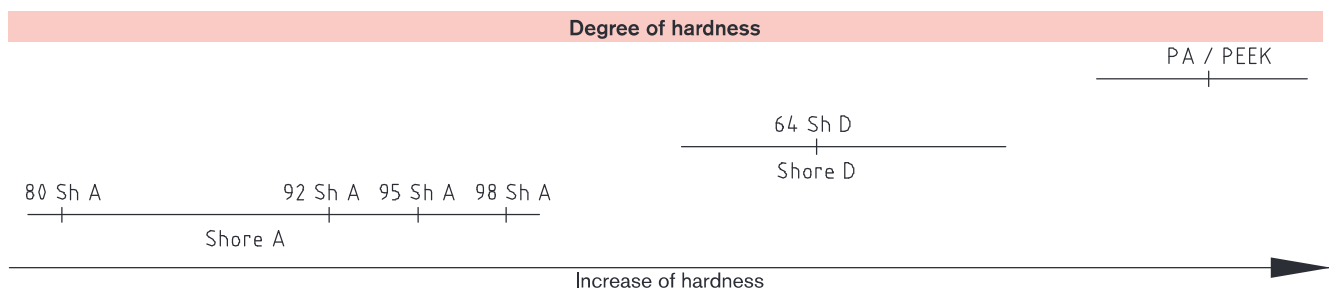

Technical data

ROTEX® sizes for all designs and materials	Max. speed [1/min] with V =		Twisting angle with		Torque [Nm]			Damping power [W] with +30 °C P _{KW}	Torsion spring stiffness C _{dyn} [$\frac{Nm}{rad}$]			
	30 m/s	40 m/s	T _{KN} φ	T _K max φ	Rated T _{KN}	Max T _K max	Vibratory T _{KW}		1,00 T _{KN}	0,75 T _{KN}	0,50 T _{KN}	0,25 T _{KN}
Spider from polyurethane 92 Shore A; colour yellow												
14	19000	–	6,4°	10°	7,5	15	2,0	–	0,38x10 ³	0,31x10 ³	0,24x10 ³	0,14x10 ³
19	14000	19000			10	20	2,6	4,8	1,28x10 ³	1,05x10 ³	0,80x10 ³	0,47x10 ³
24	10600	14000			35	70	9,1	6,6	4,86x10 ³	3,98x10 ³	3,01x10 ³	1,79x10 ³
28	8500	11800			95	190	25	8,4	10,90x10 ³	8,94x10 ³	6,76x10 ³	4,01x10 ³
38	7100	9500			190	380	49	10,2	21,05x10 ³	17,26x10 ³	13,05x10 ³	7,74x10 ³
42	6000	8000			265	530	69	12,0	23,74x10 ³	19,47x10 ³	14,72x10 ³	8,73x10 ³
48	5600	7100			310	620	81	13,8	36,70x10 ³	30,09x10 ³	22,75x10 ³	13,49x10 ³
55	4750	6300			410	820	107	15,6	50,72x10 ³	41,59x10 ³	31,45x10 ³	18,64x10 ³
65	4250	5600	3,2°	5°	625	1250	163	18,0	97,13x10 ³	79,65x10 ³	60,22x10 ³	35,70x10 ³
75	3550	4750			1280	2560	333	21,6	113,32x10 ³	92,92x10 ³	70,26x10 ³	41,65x10 ³
90	2800	3750			2400	4800	624	30,0	190,09x10 ³	155,87x10 ³	117,86x10 ³	69,86x10 ³
100	2500	3350			3300	6600	858	36,0	253,08x10 ³	207,53x10 ³	156,91x10 ³	93,01x10 ³
110	2240	3000			4800	9600	1248	42,0	311,61x10 ³	255,52x10 ³	193,20x10 ³	114,52x10 ³
125	2000	2650			6650	13300	1729	48,0	474,86x10 ³	389,39x10 ³	294,41x10 ³	174,51x10 ³
140	1800	2360			8550	17100	2223	54,6	660,49x10 ³	541,60x10 ³	409,50x10 ³	242,73x10 ³
160	1500	2000			12800	25600	3328	75,0	890,36x10 ³	730,10x10 ³	552,03x10 ³	327,21x10 ³
180	1400	1800			18650	37300	4849	78,0	2568,56x10 ³	2106,22x10 ³	1592,51x10 ³	943,95x10 ³

Spider from polyurethane 98 Shore A; from size 65 95 Shore A; colour red												
14	19000	–	6,4°	10°	12,5	25	3,3	–	0,56x10 ³	0,46x10 ³	0,35x10 ³	0,21x10 ³
19	14000	19000			17	34	4,4	4,8	2,92x10 ³	2,39x10 ³	1,81x10 ³	1,07x10 ³
24	10600	14000			60	120	16	6,6	9,93x10 ³	8,14x10 ³	6,16x10 ³	3,65x10 ³
28	8500	11800			160	320	42	8,4	26,77x10 ³	21,95x10 ³	16,60x10 ³	9,84x10 ³
38	7100	9500			325	650	85	10,2	48,57x10 ³	39,83x10 ³	30,11x10 ³	17,85x10 ³
42	6000	8000			450	900	117	12,0	54,50x10 ³	44,69x10 ³	33,79x10 ³	20,03x10 ³
48	5600	7100			525	1050	137	13,8	65,29x10 ³	53,54x10 ³	40,48x10 ³	24,00x10 ³
55	4750	6300			685	1370	178	15,6	94,97x10 ³	77,88x10 ³	58,88x10 ³	34,90x10 ³
65	4250	5600	3,2°	5°	940	1880	244	18,0	129,51x10 ³	106,20x10 ³	80,30x10 ³	47,60x10 ³
75	3550	4750			1920	3840	499	21,6	197,50x10 ³	161,95x10 ³	122,45x10 ³	72,58x10 ³
90	2800	3750			3600	7200	936	30,0	312,20x10 ³	256,00x10 ³	193,56x10 ³	114,73x10 ³
100	2500	3350			4950	9900	1287	36,0	383,26x10 ³	314,27x10 ³	237,62x10 ³	140,85x10 ³
110	2240	3000			7200	14400	1872	42,0	690,06x10 ³	565,85x10 ³	427,84x10 ³	253,60x10 ³
125	2000	2650			10000	20000	2600	48,0	1343,64x10 ³	1101,79x10 ³	833,06x10 ³	493,79x10 ³
140	1800	2360			12800	25600	3328	54,6	1424,58x10 ³	1168,16x10 ³	883,24x10 ³	523,54x10 ³
160	1500	2000			19200	38400	4992	75,0	2482,23x10 ³	2035,43x10 ³	1538,98x10 ³	912,22x10 ³
180	1400	1800			28000	56000	7280	78,0	3561,45x10 ³	2920,40x10 ³	2208,10x10 ³	1308,84x10 ³

Spider from polyurethane 64 Shore D-F; colour natural white with green tooth marking ¹⁾												
14	19000	–	4,5°	7,0°	16	32	4,2	9,0	0,76x10 ³	0,62x10 ³	0,47x10 ³	0,28x10 ³
19	14000	19000			21	42	5,5	7,2	5,35x10 ³	4,39x10 ³	3,32x10 ³	1,97x10 ³
24	10600	14000			75	150	19,5	9,9	15,11x10 ³	12,39x10 ³	9,37x10 ³	5,55x10 ³
28	8500	11800			200	400	52	12,6	27,52x10 ³	22,57x10 ³	17,06x10 ³	10,12x10 ³
38	7100	9500			405	810	105	15,3	70,15x10 ³	57,52x10 ³	43,49x10 ³	25,78x10 ³
42	6000	8000			560	1120	146	18,0	79,86x10 ³	65,49x10 ³	49,52x10 ³	29,35x10 ³
48	5600	7100			655	1310	170	20,7	95,51x10 ³	78,32x10 ³	59,22x10 ³	35,10x10 ³
55	4750	6300			825	1650	215	23,4	107,92x10 ³	88,50x10 ³	66,91x10 ³	39,66x10 ³
65	4250	5600	2,5°	3,6°	1175	2350	306	27,0	151,09x10 ³	123,90x10 ³	93,68x10 ³	55,53x10 ³
75	3550	4750			2400	4800	624	36,0	248,22x10 ³	203,54x10 ³	153,90x10 ³	91,22x10 ³
90	2800	3750			4500	9000	1170	45,0	674,52x10 ³	553,11x10 ³	418,20x10 ³	247,89x10 ³
100	2500	3350			6185	12370	1608	54,0	861,17x10 ³	706,16x10 ³	533,93x10 ³	316,48x10 ³
110	2240	3000			9000	18000	2340	63,0	1138,59x10 ³	933,64x10 ³	705,92x10 ³	418,43x10 ³
125	2000	2650			12500	25000	3250	72,0	1435,38x10 ³	1177,01x10 ³	889,93x10 ³	527,50x10 ³
140	1800	2360			16000	32000	4160	81,9	1780,73x10 ³	1460,20x10 ³	1104,05x10 ³	654,42x10 ³
160	1500	2000			24000	48000	6240	112,5	3075,80x10 ³	2522,16x10 ³	1907,00x10 ³	1130,36x10 ³
180	1400	1800			35000	70000	9100	117,0	6011,30x10 ³	4929,27x10 ³	3727,01x10 ³	2209,15x10 ³

Unless explicitly specified in your order, we will supply spiders with Shore hardness 92 A.

For peripheral speeds exceeding V = 35 m/sec., we would recommend only steel or nodular iron, respectively. Dynamic balancing required.

¹⁾ Hub material: EN-GJS-400-15 (GGG 40); steel

Spider from polyurethane	92 Shore A	95/98 Shore A	64 Shore D-F
Relative Damping ψ [-]	0,80	0,80	0,75
Resonance factor V _R [-]	7,90	7,90	8,50

Cylindrical bores and spline bores

ROTEX® Size/material		un-bored	6	8	9	10	11	12	14	15	16	17	18	19	20	22	24	25	28	30	32	35	38	40	42	45	48	50	55	60	65	70	75	80	85	90	100		
14	Sint	●		●		●	●	●	●																														
	Al-H	●	●	●	●	●	●	●	●	●	●																												
19	Sint	●							●	●	●	●	●	●	●	●																							
	Al-D	●	●	●	●	●	●	●	●	●	●	●	●	●	●	●	●																						
24	St	●							●	●	●	●	●	●	●	●	●	●	●	●	●	●	●	●	●	●	●	●	●	●	●	●	●	●	●	●	●	●	●
	Al-D	●							●	●	●	●	●	●	●	●	●	●	●	●	●	●	●	●	●	●	●	●	●	●	●	●	●	●	●	●	●	●	●
28	Al-D	●							●	●	●	●	●	●	●	●	●	●	●	●	●	●	●	●	●	●	●	●	●	●	●	●	●	●	●	●	●	●	●
	St	●							●	●	●	●	●	●	●	●	●	●	●	●	●	●	●	●	●	●	●	●	●	●	●	●	●	●	●	●	●	●	●
38	GG	●									●	●	●	●	●	●	●	●	●	●	●	●	●	●	●	●	●	●	●	●	●	●	●	●	●	●	●	●	●
	St	●															●	●	●	●	●	●	●	●	●	●	●	●	●	●	●	●	●	●	●	●	●	●	●
42	GG	●															●	●	●	●	●	●	●	●	●	●	●	●	●	●	●	●	●	●	●	●	●	●	●
	St	●																●	●	●	●	●	●	●	●	●	●	●	●	●	●	●	●	●	●	●	●	●	●
48	GG	●																●	●	●	●	●	●	●	●	●	●	●	●	●	●	●	●	●	●	●	●	●	●
	St	●																	●	●	●	●	●	●	●	●	●	●	●	●	●	●	●	●	●	●	●	●	●
55	GG	●																	●	●	●	●	●	●	●	●	●	●	●	●	●	●	●	●	●	●	●	●	●
	St	●																			●	●	●	●	●	●	●	●	●	●	●	●	●	●	●	●	●	●	●
65	GG	●																			●	●	●	●	●	●	●	●	●	●	●	●	●	●	●	●	●	●	●
	St	●																				●	●	●	●	●	●	●	●	●	●	●	●	●	●	●	●	●	●
75	GG	●																				●	●	●	●	●	●	●	●	●	●	●	●	●	●	●	●	●	●
	St	●																					●	●	●	●	●	●	●	●	●	●	●	●	●	●	●	●	●
90	GG	●																								●	●	●	●	●	●	●	●	●	●	●	●	●	●
	St	●																									●	●	●	●	●	●	●	●	●	●	●	●	●

GG = EN-GJL-250

Basic programme SAE involute spline												
Spline code	Size	Pitch circle	Pitch	No. of teeth	Angle	Spline code	Size	Pitch circle	Pitch	No. of teeth	Angle	
PH-S	5/8"	14,28	16/32	9	30°	PS-S	1 1/2"	35,98	12/24	17	30°	
PI-S	3/4"	17,46	16/32	11	30°	PD-S	1 1/2"	36,51	16/32	23	30°	
PB-S	7/8"	20,63	16/32	13	30°	PE-S	1 3/4"	42,86	16/32	27	30°	
PB-BS	1"	23,81	16/32	15	30°	PK	1 3/4"	41,275	8/16	13	30°	
PJ	1 1/8"	26,98	16/32	17	30°	PT-C	2"	47,625	8/16	15	30°	
PC-S	1 1/4"	29,63	12/24	14	30°	PQ-C	2 1/4"	53,975	8/16	17	30°	
PA-S	1 3/8"	33,33	16/32	21	30°							

Basic programme spline bores to DIN 5482									
Size	Pitch circle	Pitch	No. of teeth	Profile correctio	Size	Pitch circle	Pitch	No. of teeth	Profile correction
A 17 x 14	14,40	1,6	9	+0,600 ¹⁾	A 35 x 31	31,50	1,75	18	+0,676
A 20 x 17	19,20	1,6	12	-0,2	A 40 x 36	38,00	1,9	20	+0,049
A 25 x 22	22,40	1,6	14	+0,550	A 45 x 41	44,00	2	22	+0,181
A 28 x 25	26,25	1,75	15	+0,302	A 50 x 45	48,00	2	24	+0,181
A 30 x 27	28,00	1,75	16	+0,327					

Basic programme spline bores to DIN 5480							
Spline code	Pitch circle	Module	No. of teeth	Spline code	Pitch circle	Module	No. of teeth
20 x 1 x 18 x 7H	18,0	1	18	40 x 2 x 18 x 7H	36,0	2	18
20 x 1,25 x 14 x 7H	17,5	1,25	14	45 x 2 x 21 x 7H	41,0	2	21
25 x 1,25 x 18 x 7H	22,5	1,25	18	48 x 2 x 22 x 9H	44,0	2	22
28 x 1,25 x 21 x 7H	26,25	1,25	21	50 x 2 x 24 x 7H	48,0	2	24
30 x 2 x 13 x 7H	26,0	2	13	60 x 2 x 28 x 8H	56,0	2	28
32 x 2 x 14 x 8H	28,0	2	14	75 x 3 x 24 x 7H	72,0	3	24
35 x 2 x 16 x 8H	32,0	2	16	80 x 3 x 25 x 8H	75,0	3	25

Basic programme spline bores to DIN 9611				
Size	Width of keyway	No. of teeth	Tip circle	Root circle
1 3/8"	8,69	6	34,93	29,65

Spline clamping hubs are often adapted to the shafts of hydraulic pumps/hydraulic motors. Please ask us about the corresponding hub length of the spline code!

¹⁾ spline correction different with DIN

Inch bores and taper bores

ROTEX® Size					Stock programme inch bores										
Material					19	24	28	38	42	48	55	65	75	90	
Code	Ød	Ød Inch	b ^{+0.05}	t ₂ ^{+0.2}	St	St	St	GG	GG	GG	GG	GG	GG	GG	
Tb	9,5 ^{+0.03}	3/8	3,17	11,1											
DNB	11,11 ^{M7}	7/16	2,4	12,5											
T	12,69 ^{H7}	1/2	4,75	14,6											
Ta	12,7 ^{+0.03}	1/2	3,17	14,3	●	●									
DNC	13,45 ^{H7}	17/32	3,17	14,9											
Do	14,29 ^{+0.03}	9/16	3,17	15,6											
E	15,87 ^{+0.03}	5/8	3,17	17,5											
Es	15,88 ^{+0.03}	5/8	4,00	17,7	●	●	●								
Ed	15,87 ^{+0.03}	5/8	4,75	18,1	●	●									
DNH	17,465 ^{H7}	11/16	4,75	19,6											
Ad	19,02 ^{+0.03}	3/4	3,17	20,7											
A	19,05 ^{+0.03}	3/4	4,78	21,3	●	●	●	●							
Gs	22,22 ^{+0.03}	7/8	4,78	24,4	●										
G	22,22 ^{+0.03}	7/8	4,75	24,7	●	●	●	●	●						
F	22,22 ^{+0.03}	7/8	6,38	25,2		●	●	●	●	●					
Gd	22,225 ^{M7}	7/8	4,76	24,7		●									
Gf	23,80 ^{+0.03}	15/16	6,35	26,8											
Bs	25,38 ^{+0.03}	1	6,37	26,3		●	●	●	●						
H	25,40 ^{+0.03}	1	4,78	27,8											
Hs	25,40 ^{+0.03}	1	6,35	28,7			●								
R	26,95 ^{+0.03}	1 1/16	4,78	29,3											
Sa	28,575 ^{M7}	1 1/8	6,35	31,7	●	●									
Sb	28,58 ^{+0.03}	1 1/8	6,35	31,5		●	●								
Sd	28,58 ^{+0.03}	1 1/8	7,93	32,1											
Js	31,75 ^{+0.03}	1 1/4	6,35	34,6											
K	31,75 ^{K7}	1 1/4	7,93	35,5			●	●	●	●					
Ma	34,925 ^{M7}	1 3/8	7,93	38,7		●									
RH1	34,93 ^{M7}	1 3/8	9,55	37,8											
Cb	36,50 ^{+0.03}	1 7/16	9,55	40,9											
Ca	38,07 ^{+0.03}	1 1/2	7,93	42,0											
C	38,07 ^{+0.03}	1 1/2	9,55	42,5			●	●	●	●	●		●		
Nb	41,275 ^{M7}	1 5/8	9,55	45,8				●	●						
Ls	44,42 ^{+0.03}	1 3/4	9,55	48,8					●						
L	44,45 ^{K7}	1 3/4	11,11	49,4						●	●				
Lu	47,625 ^{M7}	1 7/8	12,7	53,5											
Da	49,20 ^{+0.03}	1 15/16	12,7	55,0											
Ds	50,77 ^{+0.03}	2	12,7	56,4											
D	50,80 ^{+0.03}	2	12,7	55,1											
Pa	53,975 ^{M7}	2 1/8	12,7	60,0									●		
U	57,10 ^{+0.03}	2 1/4	12,7	62,9											
Ub	60,325 ^{M7}	2 3/8	15,875	67,6											
Wd	85,725 ^{M7}	3 3/8	22,225	95,8											
Wf	92,075 ^{M7}	3 5/8	22,225	101,9											

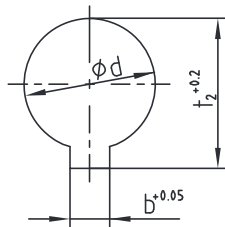

Basic programme taper 1:8					
Code	d ^{+0.05}	(d ₂)	b ^{S9}	t ₂ ^{+0.1}	l _k
...N.../ 1	9,7	7,575	2,4	10,85	17,0
...N.../ 1c	11,6	9,5375	3	12,90	16,5
...N.../ 1e	13,0	10,375	2,4	13,80	21,0
...N.../ 1d	14,0	11,813	3	15,50	17,5
...N.../ 1b	14,3	11,8625	3,2	15,65	19,5
...N.../ 2	17,287	14,287	3,2	18,24	24,0
...N.../ 2a	17,287	14,287	4	18,94	24,0
...N.../ 2b	17,287	14,287	3	18,34	24,0
...N.../ 3	22,002	18,6895	4	23,40	28,0
...N.../ 4	25,463	20,963	4,78	27,83	36,0
...N.../ 4b	25,463	20,963	5	28,23	36,0
...N.../ 4a	27,0	22,9375	4,78	28,80	32,5
...N.../ 4g	28,45	23,6375	6	29,32	38,5
...N.../ 5	33,176	27,676	6,38	35,39	44,0
...N.../ 5a	33,176	27,676	7	35,39	44,0
Basic programme taper 1:10					
CX	19,95	16,75	5	22,08	32
DX	24,95	20,45	6	26,68	45
EX	29,75	24,75	8	31,88	50

Basic programme taper 1:5					
Code	d ^{+0.05}	(d ₂)	b ^{S9}	t ₂ ^{+0.1}	l _k
A-10	9,85	7,55	2	1,0	11,5
B-17	16,85	13,15	3	1,8	18,5
C-20	19,85	15,55	4	2,2	21,5
Cs-22	21,95	17,65	3	1,8	21,5
D-25	24,85	19,821	5	2,9	26,5
E-30	29,85	23,55	6	2,6	31,5
F-35	34,85	27,55	6	2,6	36,5
G-40	39,85	32,85	6	2,6	35,0

With codes N.../6 and N.../6a parallel to taper the respective pump code should be started before ...N and the respective size of coupling before and behind ...N.../.

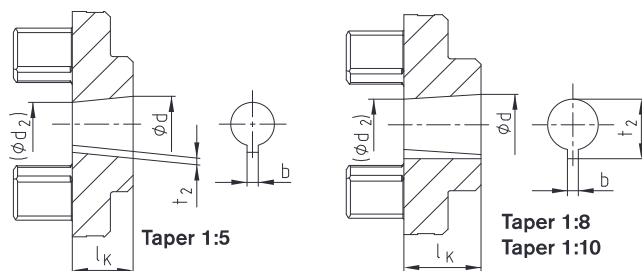

Shaft coupling design No. 001 - casted materials

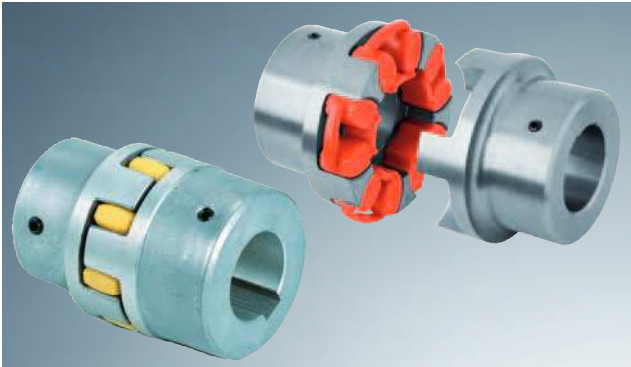

- Torsionally flexible, maintenance-free
- Damping vibrations
- Axial plug-in, fail-safe
- Allow machining – good dynamic properties
- Compact design/small flywheel effect
- Finish bore according to ISO fit H7, feather keyway according to DIN 6885 sheet 1 - JS9
- Stock programme/basic programme see pages 26 and 27
- Approved according to EC Standard 94/9/EC (without aluminium AL-D)
- Mounting instructions under www.ktr.com

Components

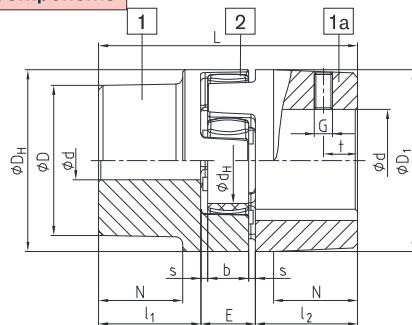

AL-D (thread opposite the keyway)

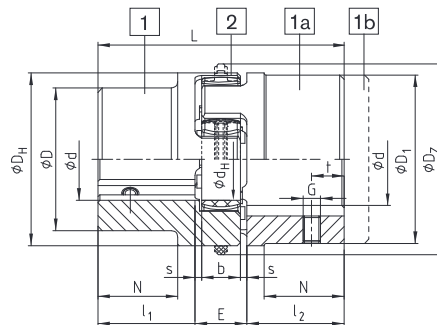

EN-GJL-250 / EN-GJS-400-15 (thread on the keyway)

Spider
as hardness 92 Sh-A
and 95/98 Sh-A
standard from size
14 - 90 and 64 Sh-D
size 14 - 180

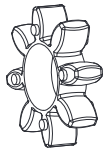

NEW
elements DZ (double
tooth elements)
as hardness 92 Sh-A
and 95 Sh-A
standard from size 100 -
180

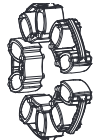

ROTEX® Aluminium diecast (AI-D)

Size	Component	Spider (part 2) ¹⁾			Dimensions [mm]														
		Rated torque [Nm]			Finish bore d (min-max)	General										Thread for setscrews			
		92 Sh A	98 Sh A	64 Sh D		L	l ₁ ; l ₂	E	b	s	D _H	D _Z	d _H	D; D ₁	N	G	t	T _A [Nm]	
14 ²⁾	1a	7,5	12,5	-	6-16	35	11	13	10	1,5	30	-	10	30	-	M4	5	1,5	
19	1	10	17	-	6-19	66	25	16	12	2	41	-	18	32	20	M5	10	2	
	19-24				41														
24	1	35	60	-	9-24	78	30	18	14	2	56	-	27	40	24	M5	10	2	
	22-28				56														
28	1	95	160	-	10-28	90	35	20	15	2,5	66	-	30	48	28	M8	15	10	
	28-38				66														

ROTEX® Cast iron EN-GJL-250 (GG 25)

Size	Component	92 Sh A	98 Sh A	64 Sh D	Rated torque [Nm]	Finish bore d (min-max)	L	l ₁ ; l ₂	E	b	s	D _H	D _Z	d _H	D; D ₁	N	G	t	T _A [Nm]
38	1	190	325	405	12-40	114	45	24	18	3	80	-	38	66	37	M8	15	10	
	1a				38-48	114	45							78					
	1b				12-48	164	70							62					
42	1	265	450	560	14-45	126	50	26	20	3	95	-	46	75	40	M8	20	10	
	1a				42-55	126	50							94					
	1b				14-55	176	75							65					
48	1	310	525	655	15-52	140	56	28	21	3,5	105	-	51	85	45	M8	20	10	
	1a				48-62	140	56							104					
	1b				15-62	188	80							69					
55	1	410	685	825	20-60	160	65	30	22	4	120	-	60	98	52	M10	20	17	
	1a				55-74	160	65							118					
65	1	625	940	1175	22-70	185	75	35	26	4,5	135	-	68	115	61	M10	20	17	
75	1	1280	1920	2400	30-80	210	85	40	30	5	160	-	80	135	69	M10	25	17	
90	1	2400	3600	4500	40-97	245	100	45	34	5,5	200	218	100	160	81	M12	30	40	

ROTEX® Nodular iron EN-GJS-400-15 (GGG 40)

Size	Component	92 Sh A	98 Sh A	64 Sh D	Rated torque [Nm]	Finish bore d (min-max)	L	l ₁ ; l ₂	E	b	s	D _H	D _Z	d _H	D; D ₁	N	G	t	T _A [Nm]
100	1	3300	4950	6185	50-115	270	110	50	38	6	225	246	113	180	89	M12	30	40	
110	1	4800	7200	9000	60-125	295	120	55	42	6,5	255	276	127	200	96	M16	35	80	
125	1	6650	10000	12500	60-145	340	140	60	46	7	290	315	147	230	112	M16	40	80	
140	1	8550	12800	16000	60-160	375	155	65	50	7,5	320	345	165	255	124	M20	45	140	
160	1	12800	19200	24000	80-185	425	175	75	57	9	370	400	190	290	140	M20	50	140	
180	1	18650	28000	35000	85-200	475	195	85	64	10,5	420	450	220	325	156	M20	50	140	

¹⁾ = If no material is mentioned in the order, the calculation/order is based on the material marked with ¹⁾ Maximum torque of the coupling T_{Kmax} = rated torque of the coupling T_{K Nenn} · x 2 ²⁾ Material AI-H.

Order form:	ROTEX®-38	GG	92	1a	-	Ø 45	1	-	Ø 25
	Coupling size	Material	Spider hardness Shore A]	Hub design	Finish bore	Hub design	Finish bore		

Shaft coupling design No. 001 - material steel



- Hubs from steel, specifically suitable for drive elements subject to high loads, e. g. steel mills, elevator drives, spline hubs, etc.)
- Torsionally flexible, maintenance-free, vibration-damping
- Axial plug-in, fail-safe
- All-over machining - good dynamic properties
- Compact design/small flywheel effect
- Finish bore according to ISO fit H7, feather keyway according to DIN 6885 sheet 1 - JS9
- Stock programme/basic programme see pages 26 and 27
- Approved according to EC Standard 94/9/EC
- Mounting instructions under www.ktr.com

Components

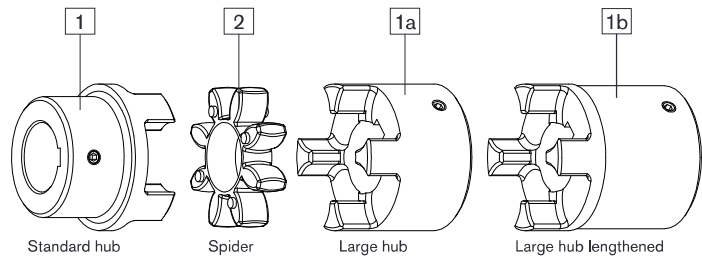
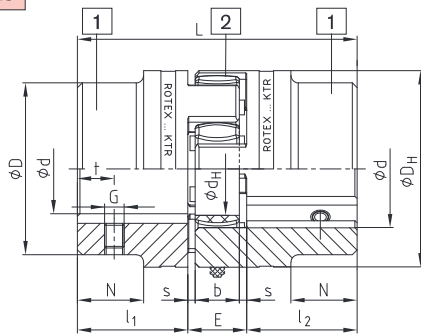

Steel (thread on the keyway)

ROTEX® steel																			
Size	Component	Spider (part 2) ¹⁾			Finish bore d (min-max)	Dimensions [mm]													
		Rated torque [Nm]				General											Thread for setscrews		
		92 Sh A	98 Sh A	64 Sh D		L	l ₁ : l ₂	E	b	s	D _H	d _H	D	N	G	t	T _A [Nm]		
14	1a	7,5	12,5	16	0-16	35	11	13	10	1,5	30	10	30	-	M4	5	1,5		
	1b					50	18,5												
19	1a	10	17	21	0-25	66	25	16	12	2	40	18	40	-	M5	10	2		
	1b					90	37												
24	1a	35	60	75	0-35	78	30	18	14	2	55	27	55	-	M5	10	2		
	1b					118	50												
28	1a	95	160	200	0-40	90	35	20	15	2,5	65	30	65	-	M8	15	10		
	1b					140	60												
38	1	190	325	405	0-48	114	45	24	18	3	80	38	70	27	M8	15	10		
	1b					164	70						80	-					
42	1	265	450	560	0-55	126	50	26	20	3	95	46	85	28	M8	20	10		
	1b					176	75						95	-					
48	1	310	525	655	0-62	140	56	28	21	3,5	105	51	95	32	M8	20	10		
	1b					188	80						105	-					
55	1	410	685	825	0-74	160	65	30	22	4	120	60	110	37	M10	20	17		
	1b					210	90						120	-					
65	1	625	940	1175	0-80	185	75	35	26	4,5	135	68	115	47	M10	20	17		
	1b					235	100						135	-					
75	1	1280	1920	2400	0-95	210	85	40	30	5	160	80	135	53	M10	25	17		
	1b					260	110						160	-					
90	1	2400	3600	4500	0-110	245	100	45	34	5,5	200	100	160	62	M12	30	40		
	1b					295	125						200	-					

ROTEX® sintered steel																		
Size	Component	Spider (part 2) ¹⁾		Finish bore d	Dimensions [mm]													
		Rated torque [Nm]			General											Thread for setscrews		
		92 Sh-A	98 Sh-A		L	l ₁ : l ₂	E	b	s	D _H	d _H	D	N	G	t	T _A [Nm]		
14	1a	7,5	12,5	unbored, 8, 10, 11, 12, 14, 15, 16	35	11	13	10	1,5	30	10	30	-	M4	5	1,5		
19	1a	10	17	unbored, 14, 16, 19, 20, 22, 24	66	25	16	12	2	40	18	40	-	M5	10	2		

¹⁾ = If no material is mentioned in the order, the calculation/order is based on the material marked with

²⁾ Maximum torque of the coupling T_{Kmax} = rated torque of the coupling T_{K Nenn} x 2

ROTEX® 19 – 48 from stainless steel available from stock

- ROTEX® 19, 28 and 42 – hub material X10CrNiS 18-9 material number 1.4305 (V2A) DIN 17440

- ROTEX® 24, 38 and 48 – hub material X6CrNiMoTi17-12-2 material number 1.4571 (V4A) DIN 17440

Order form:	ROTEX®-38	St	92	1 – Ø 45	1 – Ø 25	
	Coupling size	Material	Spider hardness Shore A]	Hub design	Finish bore	Hub design

Shaft coupling design No. 001 with Taper clamping bush



- Shaft coupling with taper clamping bush
- Sliding fit facilitates the axial alignment of the coupling
- Short mounting length
- Easy assembly/disassembly of the coupling hubs
- Extra securing by positive locking, the clamping screws are each mounted by half in the coupling hub and in the taper clamping bush

Components

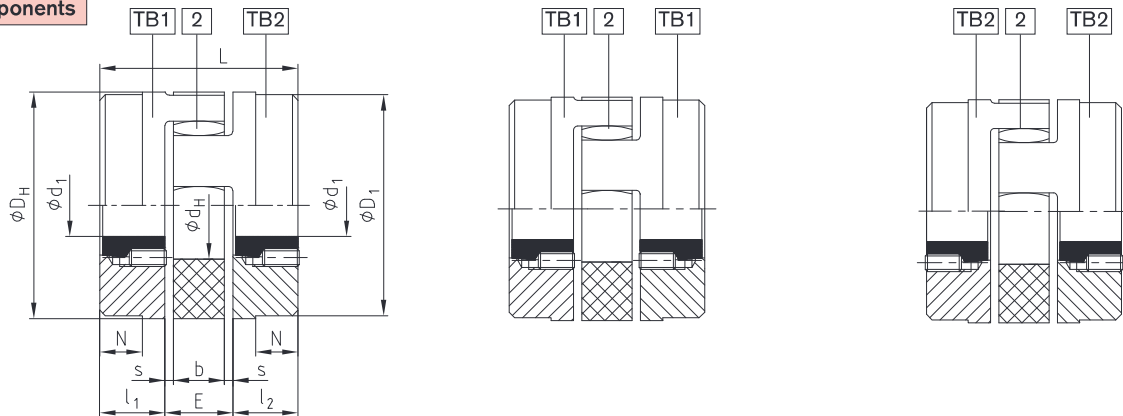

ROTEX® type No. 001 with taper clamping bush

Size	Taper clamping bush	Dimensions [mm]									Fixing screw for taper bush			
		$l_1:l_2$	E	s	b	L	N	D_H	D_1	d_H	Size [Inch]	Length [mm]	Number	T_A [Nm]
24	1008	23	18	2,0	14	64	–	55	55	27	1/4"	13	2	5,7
28	1108	23	20	2,5	15	66	–	65	65	30	1/4"	13	2	5,7
38	1108	23	24	3,0	18	70	15	80	78	38	1/4"	13	2	5,7
42	1610	26	26	3,0	20	78	16	95	94	46	3/8"	16	2	20
48	1615	39	28	3,5	21	106	28	105	104	51	3/8"	16	2	20
55	2012	33	30	4,0	22	96	20	120	118	60	7/16"	22	2	31
65	2012	33	35	4,5	26	101	19	135	115	68	7/16"	22	2	31
75	2517	52	40	5,0	30	144	36	160	158	80	1/2"	25	2	49
	* 3020										5/8"	32	2	92
90	3020	52	45	5,5	34	149	33	200	160	100	5/8"	32	2	92
125	3535	90	60	7,0	46	288	86	230	290	147	1/2"	49	3	113
	4545										3/4"	49	3	192

▪ Only available for design TB 2
* 1. BSW thread

Coupling type TB 1/1; TB 2/2; TB 1/2 possible

▪ Please order our separate dimension sheet (M 373054).

Taper clamping bush

Size	Bore dimensions d_1 available; H7 fit – keyways to DIN 6885 sheet 1																		
1008	10	11	12	14	16	18	19	20	22	24	25								
1108	10	11	12	14	16	18	19	20	22	24	25	28*							
1610	14	16	18	19	20	22	24	25	28	30	32	35	38	40	42*				
1615	14	16	18	19	20	22	24	25	28	30	32	35	38	40	42*				
2012	14	16	18	19	20	22	24	25	28	30	32	35	38	40	42	45	48	50	
2517	16	18	19	20	22	24	25	28	30	32	35	38	40	42	45	48	50	55	60
3020	25	28	30	35	38	40	42	45	48	50	55	60	65	70	75				
3535	35	38	40	42	45	48	50	55	60	65	70	75	80	85	90				
4545	55	60	65	70	75	80	85	90	95	100	105	110							

* Bores with keyway (flat design) to DIN 6885 sheet 3

Order form:

ROTEX® 38	92 Sh A	1108	TB1 – Ø 24	TB2 – Ø 22
Coupling size	Spider hardness	Taper clamping bush	Hub design Finish bore	Hub design Finish bore

Clamping ring hubs



- Torsionally flexible shaft coupling with integrated clamping system
- High smoothness of running, application up to a peripheral speed of 40 m/s
- For high friction torques (consider the selection in case of explosion protection use)
- Easy to assemble due to internal clamping screws
- Finish bore up to Ø 50 mm according to ISO fit H7, from Ø 55 mm according to ISO fit G7
- Approved according to EC Standard 94/9/EC

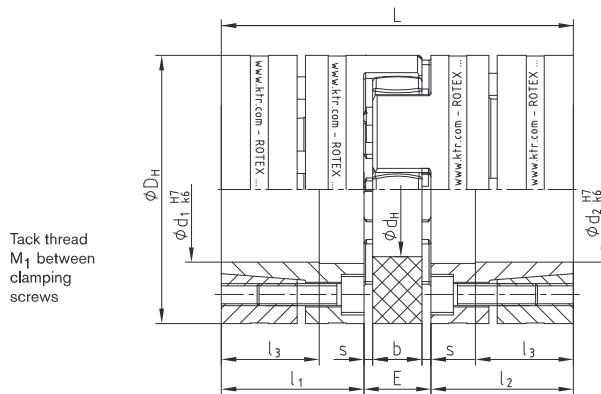

Size	Torques [Nm] ¹⁾				Dimensions [mm]									Clamping screws			Weight per hub with max. bore [kg]	Mass moment of inertia per hub with max. bore [kgm ²]	
	92 Sh A		98 Sh A		D _H ³⁾	d _H	L	l ₁ ; l ₂	l ₃	E	b	s	M	number z	T _A [Nm]	M ₁			
Hub and clamping ring material – Steel (St-H)																			
19	10,0	20	17	34	40	18	66	25	18	16	12	2,0	M4	6	4,1	M4	0,179	0,44 x 10 ⁻⁴	
24	35,0	70	60	120	55	27	78	30	22	18	14	2,0	M5	4	8,5	M5	0,399	1,91 x 10 ⁻⁴	
28	95,0	190	160	320	65	30	90	35	27	20	15	2,5	M5	8	8,5	M5	0,592	4,18 x 10 ⁻⁴	
38	190,0	380	325	650	80	38	114	45	35	24	18	3,0	M6	8	14	M6	1,225	12,9 x 10 ⁻⁴	
42	265	530	450	900	95	46	126	50	35	26	20	3,0	M8	4	35	M8	2,30	31,7 x 10 ⁻⁴	
48	310	620	525	1050	105	51	140	56	41	28	21	3,5	M10	4	69	M10	3,08	52,0 x 10 ⁻⁴	
55	375	750	685	1370	120	60	160	65	45	30	22	4,0	M10	4	69	M10	4,67	103,0 x 10 ⁻⁴	
65	-	-	940 ²⁾	1880 ²⁾	135	68	185	75	55	35	26	4,5	M12	4	120	M12	6,70	191,0 x 10 ⁻⁴	
75	-	-	1920 ²⁾	3840 ²⁾	160	80	210	85	63	40	30	5,0	M12	5	120	M12	9,90	396,8 x 10 ⁻⁴	

¹⁾ Please note coupling selection on pages 136/137 ²⁾ Figures for 95 Sh A - GS ³⁾ ØD_H + 2 mm with high speeds for expansion of spider

Bores d ₁ /d ₂ and the corresponding transmittable friction torques T _R of clamping ring hub in [Nm] ¹⁾																								
Size	Ø10	Ø11	Ø14	Ø15	Ø16	Ø19	Ø20	Ø24	Ø25	Ø28	Ø30	Ø32	Ø35	Ø38	Ø40	Ø42	Ø45	Ø48	Ø50	Ø55	Ø60	Ø65	Ø70	Ø80
19	27	32	69	84	57	94	110																	
24			70	87	56	97	114	116	133	192														
28				108	131	207	148	253	285	315	382	330	433	503										
38							208	353	395	439	531	463	603	593	689	793	776							
42									358	398	483	416	547	536	625	571	704	851	865					
48											616	704	899	896	1030	962	1160	1379	1222	1543				
55													863	856	991	918	1119	1247	1277	1672	1605	2008		
65															1446	1355	1637	1635	1827	1887	2429	2368	2930	
75																1710	2053	2059	2294	2384	3040	2983	3664	4148

The transmittable torques of the clamping connection consider the max. clearance with shaft fit k6 / bore H7, from Ø55 G7/m6. With bigger clearance the torque is reduced. For the stiffness calculation of the shaft/hollow shaft see KTR standard 45510 at our homepage www.ktr.com

Order form:	ROTEX® GS 24	98 Sh A	6.0 - Steel - Ø 24	6.0 - Steel - Ø 20
	Coupling size	Spider hardness	Hub design Finish bore	Hub design Finish bore

Clamping hubs

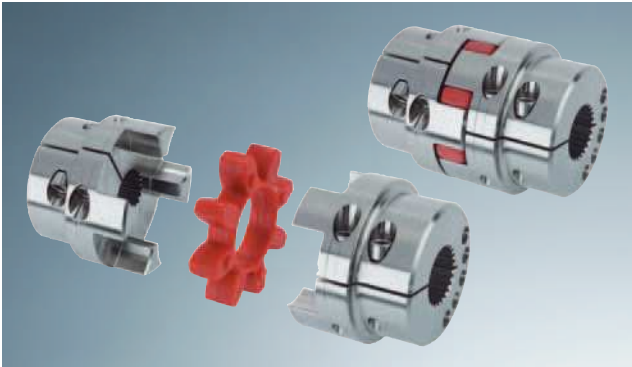

- Standard hub material steel
- Suitable in combination with spline hubs according to DIN 5480, DIN 5482, SAE J498 (see page 26) and in addition DIN 9611, DIN 5463 (ISO 14), DIN 5481 and DIN 5472
- Balanced on the basis of 3D-CAD data
- Axial plug-in, fail-safe
- Particularly suitable for applications with reversing operation
- Protection assessed and confirmed in accordance with EU standard 94/9/EC (only for hub designs 2.1 and 2.3, hub design 2.0 only according to category 3)
- Mounting instructions under www.ktr.com

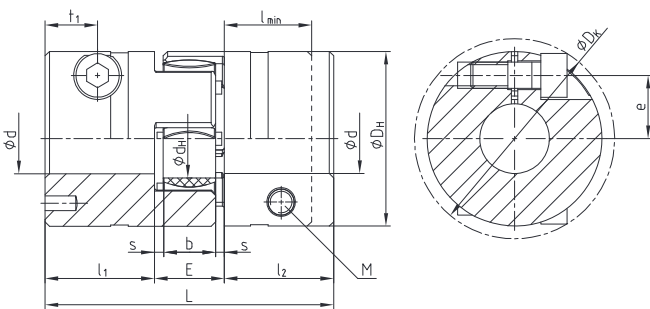

ROTEX® 19 - 28

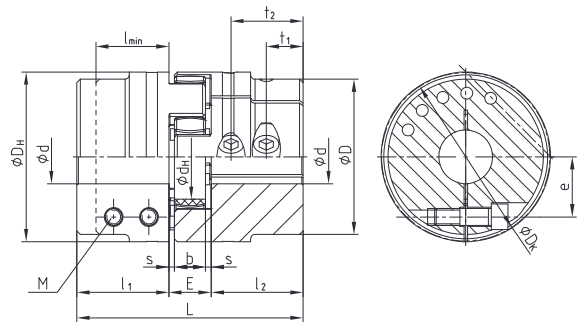

ROTEX® 38 - 90

ROTEX® with clamping hubs																
Size	Dimensions [mm]													Screw DIN EN ISO 4762		
	d _{max.}	L	l ₁ ^{1/2}	l _{min.}	E	b	s	D _H	D	d _H	D _K	t ₁	t ₂	e	M	T _A [Nm]
19	20 ¹⁾	66	25	20	16	12	2	40	-	18	46,0	12	-	14,5	M6	14
24	28	78	30	25	18	14	2	55	-	27	57,5	12	-	20,0	M6	14
28	38	90	35	30	20	15	2,5	65	-	30	73,0	14 ²⁾	-	25,0	M8	35
38	42	114	45	35	24	18	3	80	70	38	77,5	19	-	26,5	M8	35
42	50	126	50	42	26	20	3	95	85	46	93,5	18 ²⁾	-	32,0	M10	69
48	55	140	56	46	28	21	3,5	105	95	51	105,0	21 ²⁾	-	36,0	M12	120
55	68	160	65	50	30	22	4	120	110	60	119,5	26	51 ²⁾	42,5 ³⁾	M12	120
65	70	185	75	55	35	26	4,5	135	115	68	132,5	33	61 ²⁾	50,0 ³⁾	M12	120
75	80	210	85	65	40	30	5	160	135	80	158,0	36	68 ²⁾	57,0 ³⁾	M16	295
90	90	245	100	80	45	34	5,5	200	160	100	197,0	40	80 ²⁾	72,0 ³⁾	M20	580

Bore area and the corresponding transmittable friction torques [Nm] of ROTEX® clamping design 2.0																														
Size	Ø8	Ø10	Ø11	Ø14	Ø15	Ø16	Ø18	Ø19	Ø20	Ø22	Ø24	Ø25	Ø28	Ø30	Ø32	Ø35	Ø38	Ø40	Ø42	Ø45	Ø48	Ø50	Ø55	Ø60	Ø65	Ø70	Ø75	Ø80	Ø85	Ø90
19	44	46	47	51	52	53	55	57	58																					
24		59	60	64	65	66	68	70	71	73	76	77	80																	
28				139	141	144	148	150	152	157	161	163	170	174	178	185	191													
38				163	165	170	172	174	178	183	185	192	196	200	207	213	217	222												
42								291	297	304	308	318	325	332	342	353	360	367	377	387	394									
48								466	476	486	491	506	516	526	542	557	567	577	592	607	618	643								
55														1185	1215	1245	1266	1286	1316	1347	1367	1417	1468	1519						
65															1316	1347	1367	1387	1417	1448	1468	1519	1569	1620	1671					
75																		2869	2926	2983	3022	3117	3213	3309	3404	3500	3595			
90																			5220	5310	5400	5460	5610	5760	5910	6060	6210	6360	6510	6660

¹⁾ With design 2.1 d_{max.} Ø17 mm
³⁾ t₁ and t₂ have a different e dimension

²⁾ With reduced hubs the dimension t₁ varies or the number of screws changes from 2-off to 1-off

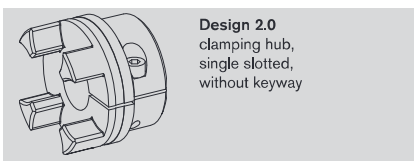

Design 2.0
clamping hub,
single slotted,
without keyway

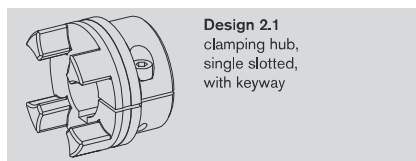

Design 2.1
clamping hub,
single slotted,
with keyway

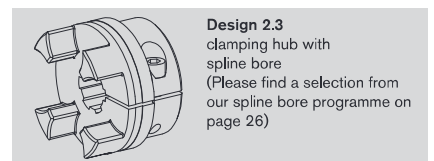

Design 2.3
clamping hub with
spline bore
(Please find a selection from
our spline bore programme on
page 26)

Order form:	ROTEX® 24	98 Sh-A	2.1	-	Ø 24	2.0	-	Ø 20
	Coupling size	Spider hardness	Hub design		Finish bore	Hub design		Finish-bore

Flange programme types AFN and BFN



- Double flange design AFN and flange design BFN applicable to heavy machinery
- Radial assembly of driving or driven machine after disassembly of driving flanges
- For design AFN - spider interchangeable while coupling installed, without removal of driving or driven machine
- Power flow can be disconnected while coupling is installed
- Flange materials: comp. 4 N steel
comp. 3 Na EN-GJS-400-15 (GGG 40)
- Finish bore according to ISO fit H7,
feather keyway according to DIN 6885 sheet 1 - JS9
- Approved according to EC Standard 94/9/EC

Components

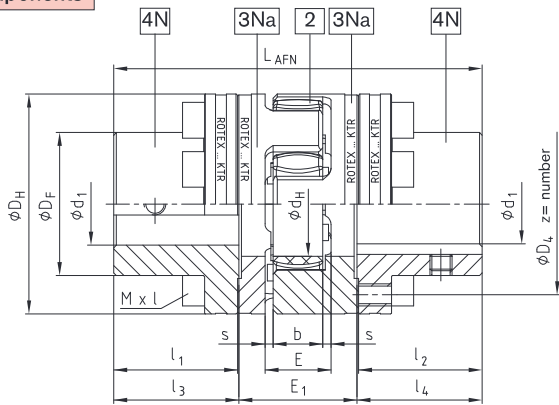

Type AFN

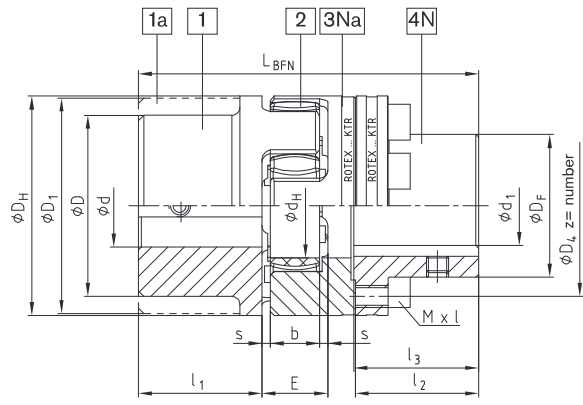

Type BFN

ROTEX® AFN (No. 002) and BFN (No. 004)

Size	Pilot bored $\varnothing d_2, \varnothing D_2$; $\varnothing D_1$	Component 4N max. finish bore $\varnothing d_1$	Dimensions [mm]											Cyl. screws ³⁾ DIN EN ISO 4762 - 12.9				
			D_H	D_F	D_4	d_H	$l_1; l_2$	E	E_1	s	b	$l_3; l_4$	L_{AFN}	L_{BFN}	Mx l	z	Pitch ²⁾	¹⁾ T_A [Nm]
24		24	55	36	45	27	30	18	33	2,0	14	30,5	94	86	M5x16	8		10
28		28	65	42	54	30	35	20	39	2,5	15	35,5	110	100	M6x20	8	8x45°	17
38		38	80	52	66	38	45	24	43	3,0	18	45,5	134	124	M8x22	8		41
42		42	95	62	80	46	50	26	48	3,0	20	51,0	150	138	M8x25	12		41
48		48	105	70	90	51	56	28	50	3,5	21	57,0	164	152	M8x25	12	16x22,5°	41
55		55	120	80	102	60	65	30	60	4,0	22	66,0	192	176	M10x30	8	8x45°	83
65		65	135	94	116	68	75	35	65	4,5	26	76,0	217	201	M10x30	12	16x22,5°	83
75		75	160	108	136	80	85	40	75	5,0	30	86,5	248	229	M12x40	15		120
90		100	200	142	172	100	100	45	82	5,5	34	101,5	285	265	M16x40	15		295
100		110	225	158	195	113	110	50	97	6,0	38	111,5	320	295	M16x50	15		295
110		125	255	178	218	127	120	55	103	6,5	42	122,0	347	321	M20x50	15	20x18°	580
125		145	290	206	252	147	140	60	116	7,0	46	142,0	400	370	M20x60	15		580
140		165	320	235	282	165	155	65	128	7,5	50	157,5	443	409	M20x60	15		580
160		190	370	270	325	190	175	75	146	9,0	57	177,5	501	463	M24x70	15		1000
180		220	420	315	375	220	195	85	159	10,5	64	198,0	555	515	M24x80	18	24x15°	1000

¹⁾ Screw tightening torque T_A [Nm].

²⁾ Thread in driving flange between cams.

³⁾ Coupling is delivered not assembled.

Order form

ROTEX® 38	AFN	92 Sh A	4N – Ø 38	4N – Ø 35
Coupling size	Type	Spider hardness	Component	Finish bore
			Component	Finish bore

Drop-out center design coupling type A-H



- Assembly/disassembly by means of 4 screws only
- Exchange of spider with no need to shift the driving and driven side (motor and pump)
- Positive-locking and frictionally engaged hub combinations to be assembled radially (dimension E_1 of design AFN = dimension E_1 of A-H)
- Finish bore according to ISO tolerance H7, feather key according to DIN 6885 sheet 1 - JS9
- Please order our separate dimension sheet (M425460)
-  Approved according to EC Standard 94/9/EC (type 7.8 shell clamping hub without feather key according to category 3)

Components

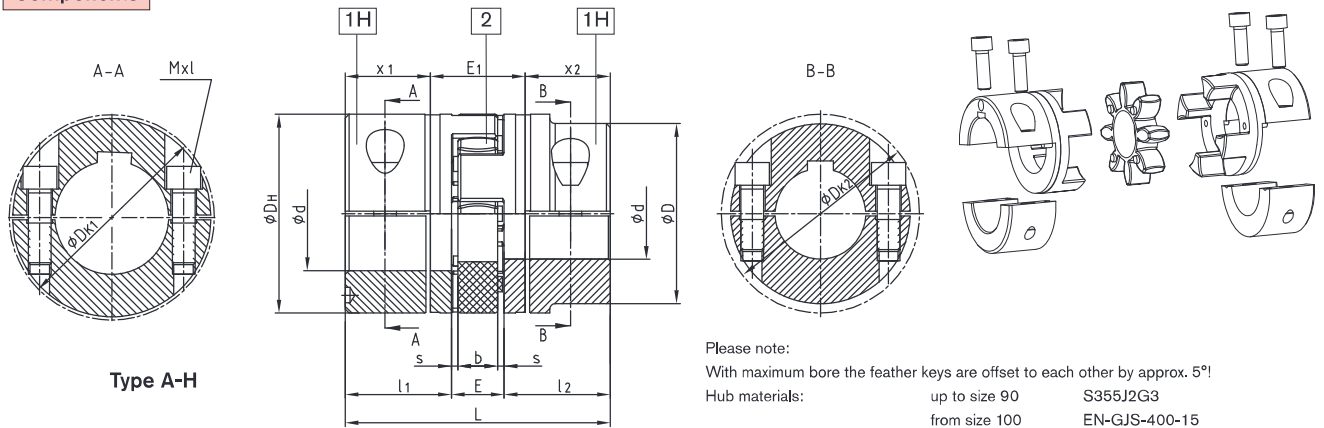

Type A-H

Please note:
With maximum bore the feather keys are offset to each other by approx. 5°!
Hub materials: up to size 90 S355J2G3
from size 100 EN-GJS-400-15

¹⁾ From size 100: 4 clamping screws for each clamping hub.

ROTEX® Type A-H																
Size	Component	Finish bore $\phi_{d_{max}}$ [mm]	Dimension [mm]											Cyl. screw DIN EN ISO 4762		
			L	$l_1; l_2$	E	b	s	D_H	D	D_{K1}	D_{K2}	x_1/x_2	E_1	Mxl	T_A [Nm]	
19	1H	20	66	25	16	12	2,0	40	-	46	-	17,5	31	M6x16	14	
24	1H	28	78	30	18	14	2,0	55	-	57,5	-	22,5	33	M6x20	14	
28	1H	38	90	35	20	15	2,5	65	-	73	-	25,5	39	M8x25	35	
38	1H	45	114	45	24	18	3,0	80	-	83,5	-	35,5	43	M8x30	35	
42	1H	50	126	50	26	20	3,0	95	85	-	93,5	39	48	M10x30	69	
		55							-	97	M10x35					
48	1H	55	140	56	28	21	3,5	105	95	-	105	45	50	M12x35	120	
		60							-	108,5	M12x40					
55	1H	65	160	65	30	22	4,0	120	110	-	119,5	50	60	M12x40	120	
		70							-	122	M12x45					
65	1H	70	185	75	35	26	4,5	135	115	-	123,5	60	65	M12x40	120	
		80							-	132,5	M12x45					
75	1H	80	210	85	40	30	5,0	160	135	-	147,5	67,5	75	M16x50	295	
		90							-	158						
90	1H	90	245	100	45	34	5,5	200	160	-	176	81,5	82	M20x60	580	
		110							-	197						
100 ¹⁾	1H	110	270	110	50	38	6,0	225	180	-	185,5	84	102	M16x50	295	
110 ¹⁾	1H	120	295	120	55	42	6,5	255	200	-	208	90	119	M20x60	580	
125 ¹⁾	1H	140	340	140	60	46	7,0	290	230	-	242,5	105	130	M24x70	1000	

Order form	ROTEX® 38	A-H	98 Sh A	7.8	-	Ø 38	7.8	-	Ø 30
	Coupling size	Type	Spider hardness	Component	Finish bore	Component	Finish bore		

Flange programme types CF, CFN, DF and DFN



- Flange designs applicable to heavy machinery
- CF and CFN - connection flange to shaft
- DF and DFN - double flange design for the connection of driving and driven machine, radial assembly possible without removal of other components ⇒ quick replacement of spider
- CFN and DFN - particularly small outside diameters
- DF and DFN – compact design
- DFN - for customer-specific mounting flanges
- Flange material part 3b: EN-GJS-400-15 (GGG 40)
- Finish bore according to ISO fit H7, feather keyway according to DIN 6885 sheet 1 - JS9
- Approved according to EC Standard 94/9/EC

Components

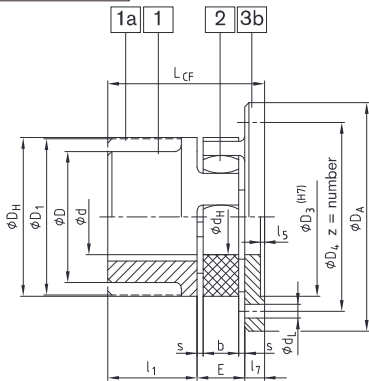

Type CF

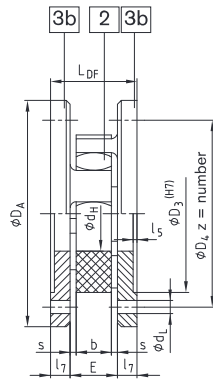

Type DF

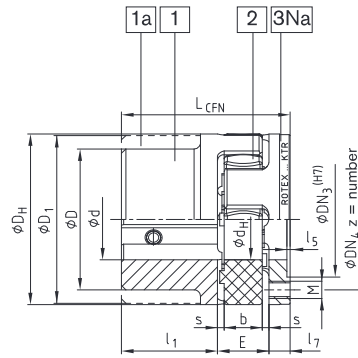

Type CFN

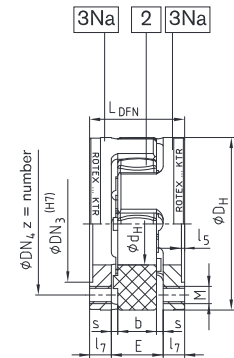

Type DFN

ROTEX® CF, CFN (No. 005) and DF, DFN (No. 006)																							
Size	Ød ØD ØD ₁	General dimension								Dimensions CF and DF						Dimensions CFN and DFN							
		D _H	d _H	l ₁	E	s	b	l ₅	l ₇	D _A	D ₃	D ₄	z	d _L	L _{CF}	L _{DF}	DN ₃	DN ₄	M	z	Pitch ²⁾	L _{CFN}	L _{DFN}
24		55	27	30	18	2,0	14	1,5	8	80	55	65	5	4,5	56	34	36	45	M5	8		56	34
28		65	30	35	20	2,5	15	1,5	10	100	65	80	6	6,6	65	40	44	54	M6	8	8x45°	65	40
38		80	38	45	24	3,0	18	1,5	10	115	80	95	6	6,6	79	44	54	66	M8	8		79	44
42		95	46	50	26	3,0	20	2,0	12	140	95	115	6	9,0	88	50	65	80	M8	12		88	50
48		105	51	56	28	3,5	21	2,0	12	150	105	125	8	9,0	96	52	75	90	M8	12	16x22,5°	96	52
55		120	60	65	30	4,0	22	2,0	16	175	120	145	8	11,0	111	62	84	102	M10	8	8x45°	111	62
65		135	68	75	35	4,5	26	2,0	16	190	135	160	10	11,0	126	67	96	116	M10	12	16x22,5°	126	67
75		160	80	85	40	5,0	30	2,5	19	215	160	185	10	13,5	144	78	112	136	M12	15		144	78
90		200	100	100	45	5,5	34	3,0	20	260	200	225	12	13,5	165	85	145	172	M16	15		165	85
100		225	113	110	50	6,0	38	4,0	25	285	225	250	12	13,5	185	100	165	195	M16	15		185	100
110		255	127	120	55	6,5	42	4,0	26	330	255	290	12	18,0	201	107	180	218	M20	15	20x18°	201	107
125		290	147	140	60	7,0	46	5,0	30	370	290	325	16	18,0	230	120	215	252	M20	15		230	120
140		320	165	155	65	7,5	50	5,0	34	410	320	360	16	22,0	254	133	245	282	M20	15		254	133
160		370	190	175	75	9,0	57	5,0	38	460	370	410	16	22,0	288	151	280	325	M24	15		288	151
180		420	220	195	85	10,5	64	5,5	40	520	420	465	16	26,0	320	165	330	375	M24	18	24x15°	320	165

Other flange dimensions see page 33

Further types: ROTEX® CF-H
Flange drop-put center design coupling

Please order our separate dimension sheet (M41 2069)

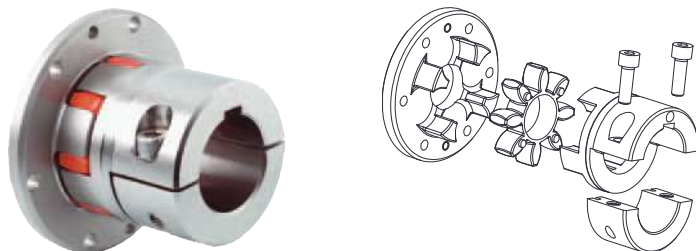

Order form:	ROTEX® 38	CF	92 Sh A	1 — EN-GJL-250 — Ø 20
	Coupling size	Type	Spider hardness	Component material Finish bore

Double cardanic type ZS-DKM-H

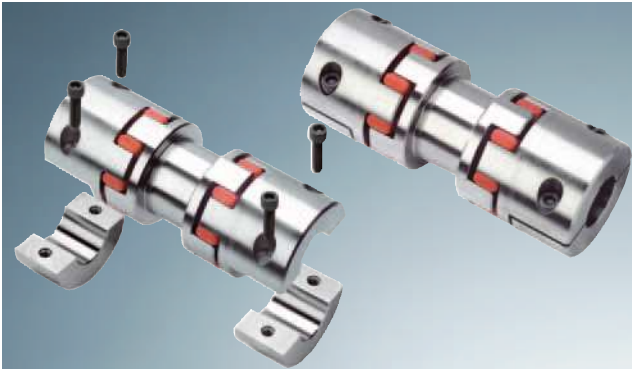

- Standard spacers up to 250 mm shaft distance dimension – ex stock
- Assembly/disassembly through 4 screws only
- Compensates for high shaft displacements due to double-cardanic design
- Remains torsionally symmetric in case of shaft displacements
- Reduced vibration and noise
- Low restoring forces ⇒ Increase of the total lifetime of all adjacent components (bearings, seals etc.)
- Approved according to EC Standard 94/9/EC (Explosion Certificate ATEX 95) (type 7.6 marked at stock, type 7.5 shell clamping hub without feather key according to category 3)

Components

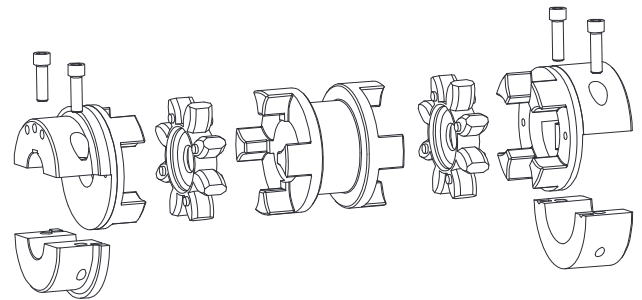
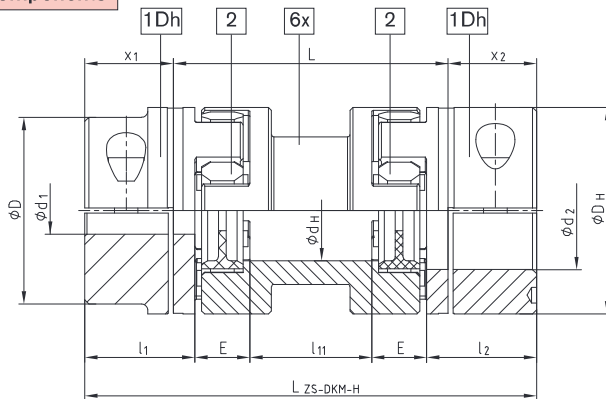

Type ZS-DKM-H

ROTEX® ZS-DKM-H																		
Size	Dismountable length L [mm]	Finish bore-max. $\varnothing d_1/d_2$ [mm]	Spider (part 2) ¹⁾ T_{KN} [Nm]	Dimensions [mm]							Cap screw DIN EN ISO 4762-12.9		Max. displacements				Weight ²⁾ [kg]	
				D_H	d_H	$l_1; l_2$	$x_1; x_2$	l_{11}	E	L ZS-DKM-H	M	T_A [Nm]	Axial [mm]	at n = 1500 rpm		at n = 3000 rpm		
													Radial [mm]	Angular [°]	Radial [mm]	Angular [°]		
24	100	28	35	55	27	30	22,5	49	18	145	M6	14	1,4	1,17		0,87		1,40
	89							185		1,87				1,40				
28	100	38	95	65	30	35	25,5	41	20	151	M8	35	1,5	1,06		0,80		1,90
	81							191		1,76				1,32		2,20		
38	100	45	190	80	38	45	35,5	33	24	171	M8	35	1,8	0,99		0,74		3,90
	73							211		1,69				1,27		4,10		
42	100	55	265	95	46	50	39,0	26	26	178	M10	69	2,0	0,91		0,68		5,10
	66							218		1,60				1,20		5,70		
48	100	60	310	105	51	56	45,0	22	28	190	M12	120	2,1	0,87		0,65		7,10
	62							230		1,57				1,18		7,90		
55	100	70	410	120	60	65	50,0	10	30	200	M12	120	2,2	0,70	1,0	0,52	0,75	9,50
	50							240		1,40				1,05		11,20		
	90							280		2,09				1,57		12,30		
	110							300		2,44				1,83		12,80		
65	140	80	625	135	68	75	60,0	40	35	260	M12	120	2,6	1,31		0,98		16,10
	80							300		2,00				1,50		16,80		
75	140	90	1280	160	80	85	67,5	25	40	275	M16	295	3,0	1,13		0,85		23,60
	65							315		1,83				1,37		26,00		
	85							335		2,19				1,64		27,00		
90	180	110	2400	200	100	100	81,5	53	45	343	M20	580	3,4	1,71		1,28		48,90
	123							413		2,93				2,19		52,60		
	250																	

1) Maximum torque of coupling $T_{Kmax.}$ = nominal torque of coupling $T_{KN} \times 2$
Size 24 to 75 spider type 95/98 Sh A-GS; at size 90 spider type 95 Sh A with inner ring
ZS-DKM-H: transmittable torque according to 92 Sh A-GS

2) Refer to max. bore

Finish bore according to ISO fit H7, feather keyway according to DIN 6885 sheet 1 - JS9

ATTENTION: The standard line is only for the horizontal assembly. Vertical assembly on request.

Order form	ROTEX® 38	ZS-DKM-H	140	98 Sh A-GS	$\varnothing 38$	$\varnothing 30$
	Coupling size	Type	Shaft distance dimension L	Spider hardness	Finish bore	Finish bore

Double cardanic type DKM



- For high shaft displacements, 3-part double-cardanic
- Reduced vibration and noise
- The restoring forces resulting from displacements are very low
- Increase of the total lifetime of all adjacent components (bearings, seals etc.)
- Approved according to EC Standard 94/9/EC (Explosion Certificate ATEX 95)
- Mounting instructions under www.ktr.com
- Double-cardanic design without the need for bearing support or external guarding

Components

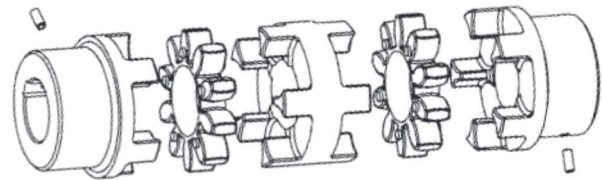
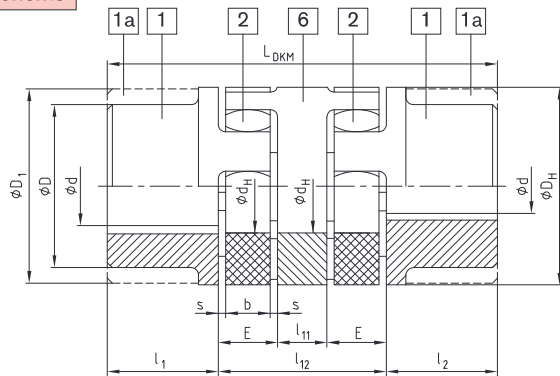

Type DKM

ROTEX® DKM (No. 018)															
Size	Ød ØD ØD ₁	Spider (part 2) Nominal torque [Nm]		Dimensions [mm]									Max. displacements at n = 1500 rpm		
		92 Sh-A	98 Sh-A	D _H	d _H	l ₁ ; l ₂	l ₁₁	l ₁₂	E	s	b	L _{DKM}	Radial [mm]	Angular [°]	Axial [mm]
19	see shaft coupling page 26 and 29; stock programme/basic programme page 26 and 27	10	17	40	18	25	10	42	16	2,0	12	92	0,45	1,0	+1,2/-1,0
24		35	60	55	27	30	16	52	18	2,0	14	112	0,59	1,0	+1,4/-1,0
28		95	160	65	30	35	18	58	20	2,5	15	128	0,66	1,0	+1,5/-1,4
38		190	325	80	38	45	20	68	24	3,0	18	158	0,77	1,0	+1,8/-1,4
42		265	450	95	46	50	22	74	26	3,0	20	174	0,84	1,0	+2,0/-2,0
48		310	525	105	51	56	24	80	28	3,5	21	192	0,91	1,0	+2,1/-2,0
55		410	685	120	60	65	28	88	30	4,0	22	218	1,01	1,0	+2,2/-2,0
65		625	940	135	68	75	32	102	35	4,5	26	252	1,17	1,0	+2,6/-2,0
75		1280	1920	160	80	85	36	116	40	5,0	30	286	1,33	1,0	+3,0/-3,0
90		2400	3600	200	100	100	40	130	45	5,5	34	330	1,48	1,0	+3,4/-3,0

Finish bore according to ISO fit H7, feather keyway according to DIN 6885 sheet 1 - JS9

Order form:	ROTEX® 38	DKM	EN-GJL-250	98 Sh A	1 — Ø 38	1 — Ø 30
	Coupling size	Type	Material	Spider hardness	Comp- onent Finish- bore	Comp- onent Finish- bore

Intermediate shaft programme type ZR

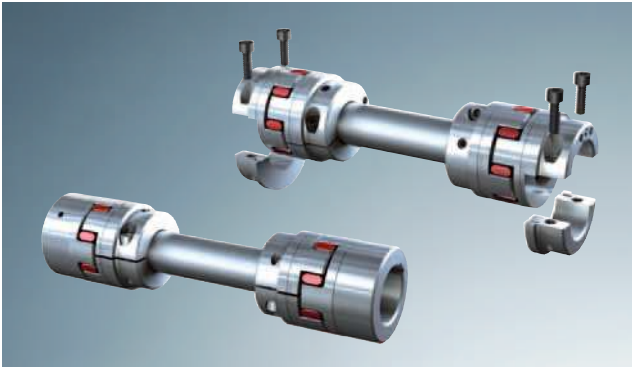

- To connect shaft ends with extended shaft separations
- Compensating for high shaft displacements due to the double-cardanic design
- Radial assembly possible without displacement of the driving or driven machine
- Particularly easy maintenance when using the semi-shell clamping hubs (type 7.5 and 7.6)
- Flexible bearing in backlash-free ROTEX® GS spiders

Components

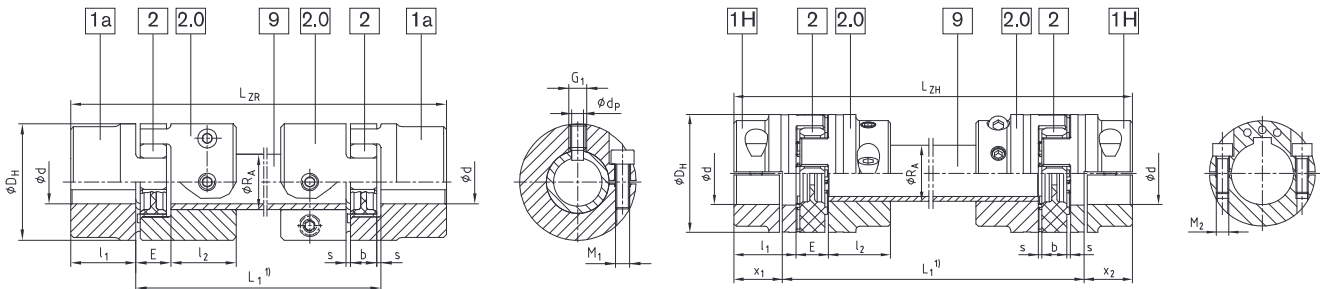

Type ZR with GS spider

Type ZR with clamping hub DH

ROTEX® type ZR (No. 037)																			
Size	Finish bore $\phi_{d_{max}}$		Dimensions [mm]						Intermediate pipe Torsional stiffness/m		Clamping screw Component 2.0		Clamping screw Component 1H		$L_{ZR}; L_{ZH}$	Locking screw G_1	Locking pin d_p [mm]	Axial displacement [mm]	Angular displacement [degrees]
	Component 1a	Component 1H	D_H	$l_1; l_2$	$x_1; x_2$	E	s	b	R_A	$C^{(2)}$ [Nm ² /rad]	M_1	T_A [Nm]	M_2	T_A [Nm]					
19	25	20	40	25	17,5	16	2,0	12	$\emptyset 20 \times 3$	954,9	M6	14	M6	10	$L_{ZR} = L_1 + 2 \cdot l_1$ $L_{ZH} = L_1 + 2 \cdot x_1$	M6	4,0	1,2	0,9
24	35	28	55	30	22,5	18	2,0	14	$\emptyset 30 \times 4$	4522	M6	14	M6	14		M8	5,5	1,4	0,9
28	40	38	65	35	25,5	20	2,5	15	$\emptyset 35 \times 4$	7611	M8	35	M8	35	M10	7,0	1,5	0,9	
38	48	45	80	45	35,5	24	3,0	18	$\emptyset 40 \times 4$	11870	M8	35	M8	35	M12	8,5	1,8	1,0	
42	55	55	95	50	39,0	26	3,0	20	$\emptyset 45 \times 4$	17487	M10	69	M10	69	M12	8,5	2,0	1,0	
48	62	60	105	56	45,0	28	3,5	21	$\emptyset 50 \times 4$	24648	M12	120	M12	120	M16	12	2,1	1,1	
55	74	70	120	65	50,0	30	4,0	22	$\emptyset 55 \times 4$	39662	M12	120	M12	120	M16	12	2,2	1,1	
65	80	80	135	75	60,0	35	4,5	26	$\emptyset 65 \times 5$	68329	M12	120	M12	120	M16	12	2,6	1,2	
75	95	90	160	85	67,5	40	4,0	30	$\emptyset 75 \times 5$	108000	M16	295	M16	295	M16	12	3,0	1,2	

¹⁾ Please indicate the shaft distance dimension L_1 in all inquiries and orders along with the maximum speed to review the critical whirling speed.

²⁾ Torsion spring stiffness when the intermediate pipe is 1m
Finish bore according to ISO fit H7, feather keyway according to DIN 6885 sheet 1 - JS9

Friction torques of clamping hubs have to be observed.

Please order dimension sheet no. 5020/000/017-757537.



Diagramme for coupling selection:

Order form:	ROTEX® 38	ZR	1200	St / EN-GJL-250	98 Sh A-GS	1H —	$\emptyset 38$	1H —	$\emptyset 30$
	Coupling size	Type	Shaft distance dim. L_1	Material	Spider hardness	Component	Finish bore	Component	Finish bore

Type BTAN with brake drum/type SBAN with disk brake

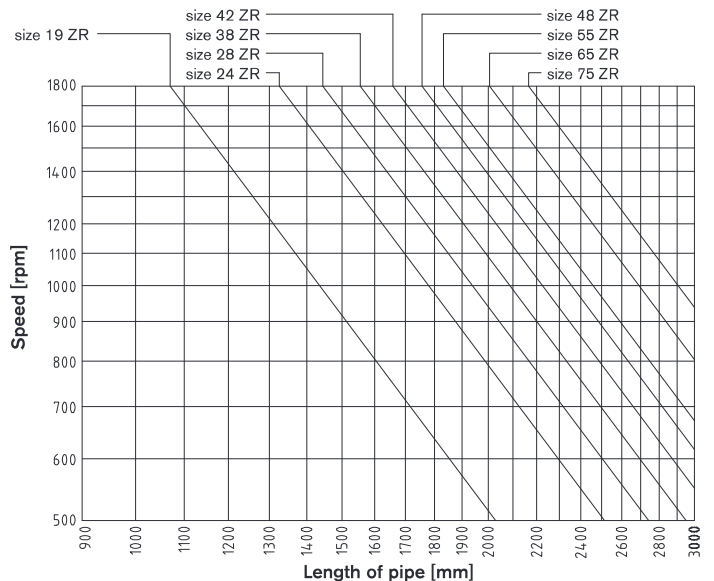

- Shaft coupling BTAN with brake drum to be mounted to external drum brakes with double shoes according to DIN 5431/15435
- Shaft coupling BTAN with disk for braking calipers
- Each coupling type to be combined with various sizes of brake drum disks (see dimension "N")
- The brake drum or disk brake has to be placed onto the shaft end with the biggest mass moment of inertia
- The maximum brake torque must not exceed the maximum torque of the coupling
- Designs BTAN and SBAN - modification for customer from the stock programme
- Mounting instructions under www.ktr.com

Components

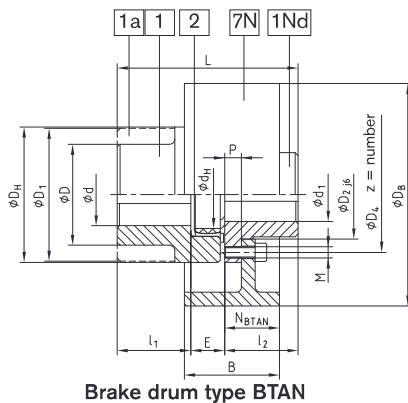

Brake drum type BTAN

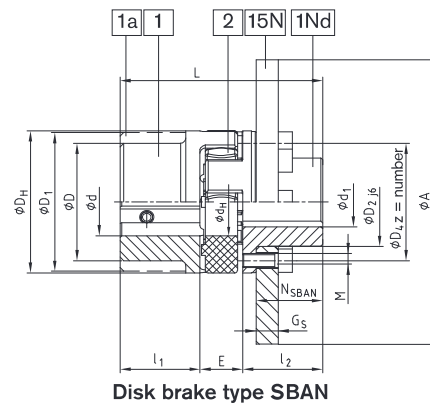

Disk brake type SBAN

ROTEX® type BTAN (No. 011) and SBAN (No. 013)

Size	Pilot bore ϕd ; ϕD ϕD_1	Finish bore max. d_1		Dimensions [mm]													
		EN-GJS-400-15	Steel	D_H	D_2	D_4	d_H	z	pitch ¹⁾	M	T_A [Nm]	$l_1; l_2$	E	L	P	N_{SBAN}	
38	—	—	34	80	50	66	38	8	8 x 45°	M8	41	45	24	114	7,5	37,5	
42	—	—	42	95	60	80	46	12	16 x 22,5°	M8	41	50	26	126	9,5	40,5	
48	—	—	48	105	68	90	51	12	8 x 45°	M10	83	65	30	160	12,5	52,5	
55	—	—	55	120	78	102	60	8	16 x 22,5°	M10	83	75	35	185	13,5	61,5	
65	—	—	65	135	92	116	68	12	—	M12	120	85	40	210	15,5	69,5	
75	—	—	75	160	106	136	80	15	—	M16	295	100	45	245	18,5	81,5	
90	—	—	100	200	140	172	100	15	20 x 18°	M16	295	110	50	270	20,5	89,5	
100	100	—	—	225	156	195	113	15	—	M20	580	120	55	295	23,5	96,5	
110	110	—	—	255	176	218	127	15	—	M20	580	140	60	340	27,5	112,5	
125	130	—	—	290	204	252	147	15	—	—	—	—	—	—	—	—	

¹⁾ Thread in the hub between the cams

Type BTAN										Type SBAN											
Brake drum	ROTEX® BTAN dimension „N _{BTAN} “									Speed rpm [V] (30 m/s)	Disk brake	ROTEX® SBAN coupling/disk brake dimension									Speed rpm [V] (30 m/s)
	38	42	48	55	65	75	90	100	110			125	38	42	48	55	65	75	90	100	
160x60	31									3550	200x12,5	x								2800	
200x75	36	38	39	41						2800	250x12,5	x	x	x						2240	
250x95	44	46	47	49	50	52				2240	315x16	x	x	x	x					1800	
315x118		55	56	58	59	61	64			1800	400x16			x	x	x	x	x	x	1400	
400x150		68	69	71	72	74	77	79	82	1400	500x16				x	x	x	x	x	1120	
500x190					87	89	92	94	97	101	1120	630x20				x	x	x	x	900	
630x236						107	110	112	115	119	900	710x20				x	x	x	x	800	
710x265										123	126	130	800	800x25				x	x	x	710
800x300										144	710	900x25							x	x	630

Other sizes on request according to dimension sheet no.:
 BTAN: M 380821
 SBAN straight: M380822; cranked: M 370065
 FNN hub: M 380823

Finish bore according to ISO fit H7, feather keyway according to DIN 6885 sheet 1 - JS9

Order form:	ROTEX® 38	BTAN	Ø200x75	92 Sh A	1Nd —	Ø 38	1 —	Ø 30
	Coupling size	Type	Ø Brake drum x width of brake drum	Spider hardness	Component	Finish bore	Component	Finish bore

Type AFN-SB special with disk brake

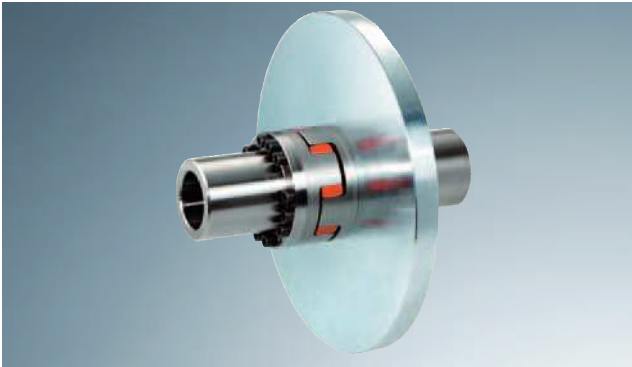

- Shaft coupling AFN-SB special with disk brake for braking calipers
- The disk brake has to be placed onto the shaft end with the biggest mass moment of inertia
- The maximum braking torque must not exceed the maximum torque of the coupling
- For details about ROTEX AFN-SB spec. please see our dimension sheet no. M 351054
- Finish bore according to ISO fit H7, feather keyway according to DIN 6885 sheet 1 - JS9
- Mounting instructions under www.ktr.com

Components

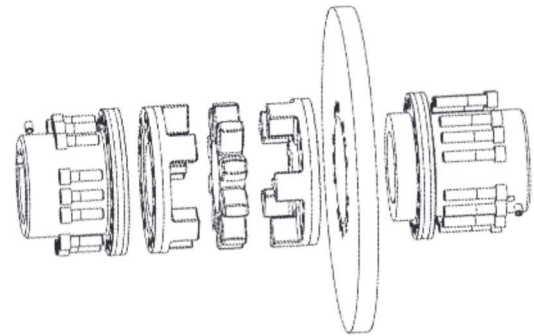
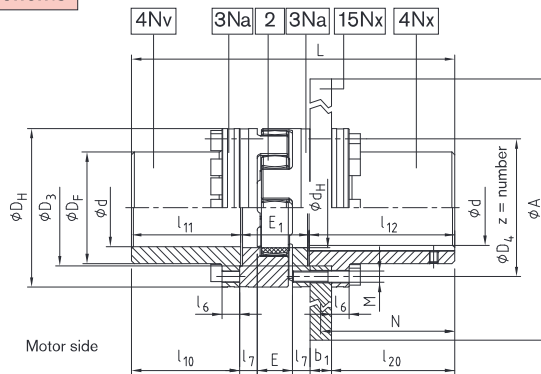

ROTEX® Type AFN-SB special

Size	Finish bore d		Dimensions [mm]										
	min.	max.	D _H	D _F	D ₃ ^{H7/h7}	D ₄	d _H	E	E ₁	M	z	Pitch	T _A [Nm]
65	22	65	135	94	96	116	68	35	65	M10	12	16x22,5°	83
75	30	75	160	108	112	136	80	40	75	M12	15		120
90	40	100	200	142	145	172	100	45	82	M16	15		295
100	46	110	225	158	165	195	113	50	97	M16	15		295
110	60	125	255	178	180	218	127	55	103	M20	15	20x18°	580
125	60	145	290	206	215	252	147	60	116	M20	15		580
140	60	165	320	235	245	282	165	65	128	M20	15		580
160	80	190	370	270	280	325	190	75	146	M24	15		1000

ROTEX® Type AFN-SB special

Size	Torque ¹⁾ mit 95Sh-A		Max. speed [rpm]	Max. ¹⁾ brake torque [Nm]	Dimensions [mm]							
	T _{KN}	T _{Kmax.}			l ₆	l ₇	l ₁₀	l ₁₁	l ₁₂	l ₂₀	N	L
65	940	1880	3450	1880	15	16	112,5	113,5	166,0	135	150	344,5
75	1920	3840	3250	3840	20	19	131,5	133,0	166,5	135	150	374,5
90	3600	7200	3000	7200	20	20	164,0	165,5	206,5	175	190	454,0
100	4950	9900	2800	9900	25	25	153,5	155,0	206,5	175	190	458,5
110	7200	14400	2600	14400	25	26	201,5	203,5	212,0	180	195	518,5
125	10000	20000	2250	20000	30	30	198,5	200,5	212,0	180	195	528,5
140	12800	25600	1800	25600	30	34	244,5	247,0	252,5	220	235	627,5
										210 ²⁾	230 ²⁾	
160	19200	38400	1500	38400	34	38	226,5	229,0	252,5	220	235	627,5
										210 ²⁾	230 ²⁾	

Selection of ROTEX® coupling/disk brake

Size	Brake disk $\varnothing A \times b_1$										
	355x30	400x30	450x30	500x30	560x30	630x30	710x30	800x30	900x30	900x40	1000x40
65	x	x	x								
75		x	x	x							
90			x	x	x	x					
100				x	x	x					
110				x	x	x	x				
125						x	x	x			
140							x	x	x	x	x
160							x	x	x	x	x

¹⁾ The max. braking torque must not exceed the maximum torque of the coupling. ²⁾ Dimensions for a brake disk width b_1 of 40 mm.

Order form:

ROTEX® 90	AFN-SB special	$\varnothing 200 \times 75$	95 Sh A	4Nv – $\varnothing 90$	4Nx – $\varnothing 90$		
Coupling size	Type	\varnothing Disk brake width of disk	Spider hardness	Component	Finish bore	Component	Finish bore

Type SD (shiftable at standstill)



- Shiftable shaft coupling for all applications in general engineering
- Easy to engage and disengage driving or driven machines with standstill of machine
- Existing shifting hub to be combined with slip ring and shiftable linkage
- With pilot bored shifting hubs the requested shifting force must be set after final machining
- Other sizes on request according to M 370266
- Complete shifting device consisting of:
separated slip ring from red bronze, shift fork, shifting shaft, shifting lever, eye type bearing

Components

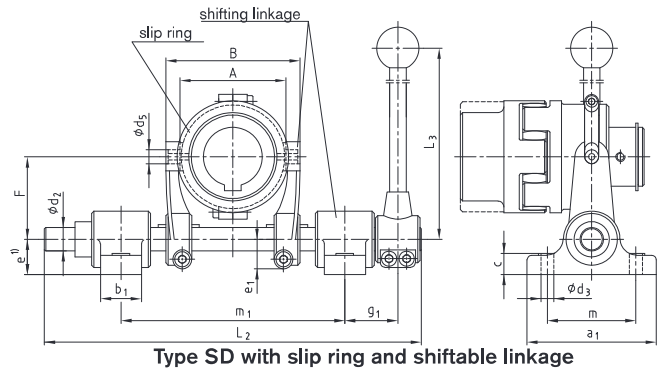
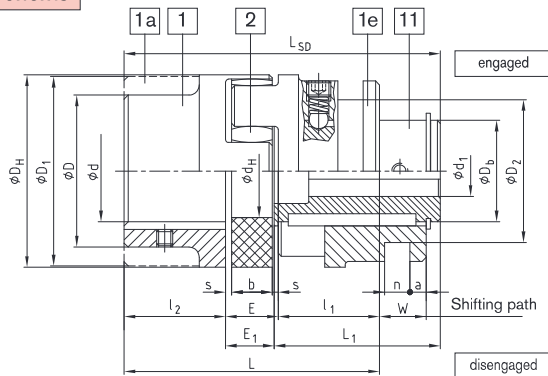

ROTEX® type SD (No. 015)

Size	φd φD1	Finish bore d1		Dimensions [mm]																Shifting force set in [N]	Slip ring size	Shiftable linkage size
		min.	max.	D _H	D ₂ ±0,1	D _b	d _H	l ₁ ·l ₂	E	s	b	E ₁	L	L ₁	W	a	n±0,1	L _{SD}				
24	8	18	55	41	30	27	30	18	2,0	14	16,5	78	51,5	16,0	6	6,0	98	110	—	—		
28	10	22	65	58	36	30	35	20	2,5	15	18,0	90	60,0	17,5	8	8,0	113	130	—	—		
38	12	28	80	70,5	45	38	45	24	3,0	18	22,0	114	73,0	21,0	8	12,5	140	150	1,1	1		
42	14	32	95	70,5	50	46	50	26	3,0	20	24,0	126	82,0	23,0	8	12,5	156	180	1,1	1		
48	15	40	105	89,5	60	51	56	28	3,5	21	25,5	140	90,5	24,5	6	17,5	172	200	2,2	2		
55	18	48	120	112,5	70	60	65	30	4,0	22	27,0	160	103,0	26,0	6	18,0	195	250	3,3	3		
65	20	55	135	112,5	80	68	75	35	4,5	26	32,0	185	120,0	30,5	7	18,0	227	280	3,3	3		
75	25	65	160	130,5	95	80	85	40	5,0	30	37,0	210	135,0	35,0	6	20,5	257	350	4,4	3		
90	28	75	200	164,5	110	100	100	45	5,5	34	41,0	245	152,0	39,5	8	25,5	293	350	5,5	4		
100	30	80	225	164,5	115	113	110	50	6,0	38	46,0	270	169,0	44,0	14	25,5	325	380	5,5	4		
110	35	85	255	164,5	125	127	120	55	6,5	42	51,5	295	184,0	48,5	18,5	25,5	355	450	5,5	4		
125	40	100	290	210,5	145	147	140	60	7,0	46	55,5	340	208,5	53,0	18,5	30,5	404	500	6,6	5		

slip ring and shiftable linkage

Size	Shiftable linkage size	Dimensions [mm]																Max. speed n for slip ring [rpm]		
		a ₁	b ₁	c	d ₂	d ₃	d ₅	e ¹⁾	e ₁	F	g ₁	L ₂	L ₃	m	m ₁ min.	m ₁ max.	A		B	
38	1	110	35	18	20	11	12	30	25	70	55	320	400	75	180	190	90	114	3280	
42	1																			
48	2				25				27	97,5	60	430	450		240	270	111	151	2550	
55	3																			
65	3	140	40		30		17	40	32,5	120	70	490	600	100	280	310	140	180	2120	
75	3			25													170	210	1710	
90	4																			
100	4				35			21	37,5	147,5	70	565	750		321	365	200	244	1360	
110	4	160	45					50						120						
125	5				40			25	46	190	80	630	1068		365	410	250	300	855	

¹⁾ In case of a through base plate the dimension "e" of the shiftable linkage size 5 has to be increased by at least 10 mm.

Finish bore according to ISO fit H7, feather keyway according to DIN 6885 sheet 1 - JS9

Order form:

ROTEX® 38	SD	with 1,1 and 1	92 Sh A	1 —	Ø 38	11 —	Ø 28
Couplings size	Type	with slip ring 1,1 and shiftable linkage 1	Spider hardness	Component	Finish bore	Component	Finish bore

Type FNN and FNN with fan

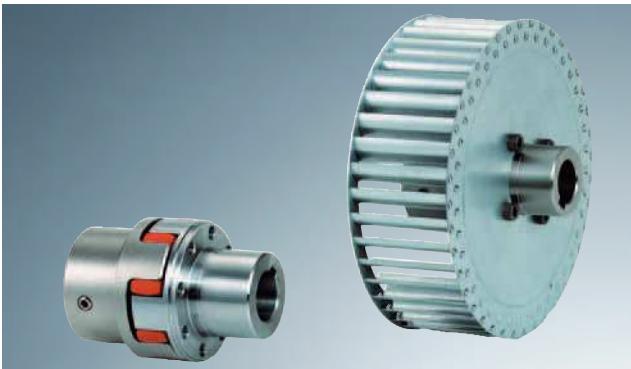

- Damping vibrations and reducing noise
- Ideal compensation for misalignment due to crowned teeth
- Coupling as plug-in design
- Easy checking of wear by sight control
- Coupling to be equipped with any fan
- Finish bore according to ISO fit H7, feather keyway according to DIN 6885 sheet 1 - JS9

Components

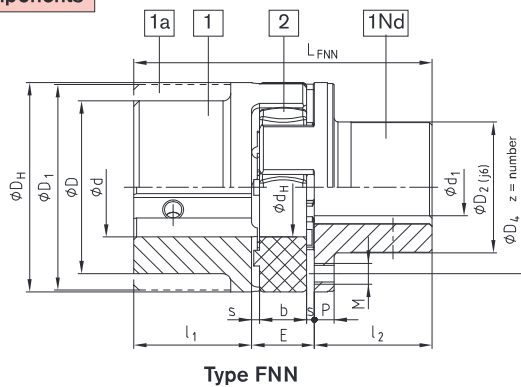

Type FNN

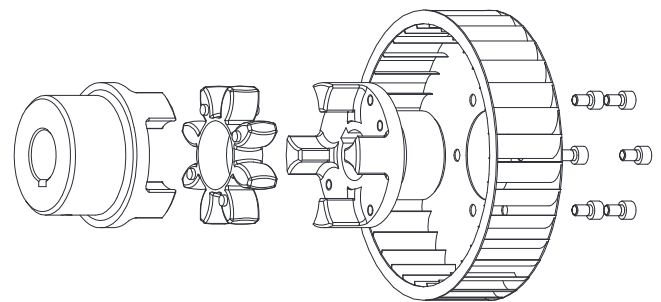

Type FNN with fan (typ 1)

ROTEX® type FNN (No. 021)

Size	ϕd ϕD ϕD_1	max. finish bore ϕd_1	Dimensions [mm]												
			D_H	D_2	D_4	d_H	E	s	b	l_1, l_2	P	M	z	Pitch	L_{FNN}
28		24	65	40	54	30	20	2,5	15	35	6,5	M6	8		90
38		34	80	50	66	38	24	3,0	18	45	7,5	M8	8	8x45°	114
42		42	95	60	80	46	26	3,0	20	50	9,5	M8	12	16x22,5°	126
48		48	105	68	90	51	28	3,5	21	56	10,5	M8	12		140
55		55	120	78	102	60	30	4,0	22	65	12,5	M10	8	8x45°	160
65		65	135	92	116	68	35	4,5	26	75	13,5	M10	12	16x22,5°	185
75		75	160	106	136	80	40	5,0	30	85	15,5	M12	15		210
90		100	200	140	172	100	45	5,5	34	100	18,5	M16	15	20x18°	245

Other sizes on request

Type 1: Fan screwed on

The ROTEX® coupling can be supplied with the fan screwed on. Specific connection dimensions of customers such as pitch circle of threads, size of threads and number of centering of fans should be mentioned in your inquiry.



Type 2: Fans injection-moulded

Low prices due to production volumes depending on quantity.



Type 3: Fans pressed or glued on

Special surface forming (knurling according to DIN 82) allows the fan to be pressed or glued onto the hub collar.



Order form:

ROTEX® 38	FNN	92 Sh A	1 —	∅ 38	1Nd —	∅ 30
Couplings size	Type	Spider hardness	Component	Finish bore	Component	Finish bore

Further types with clamping sets

Components

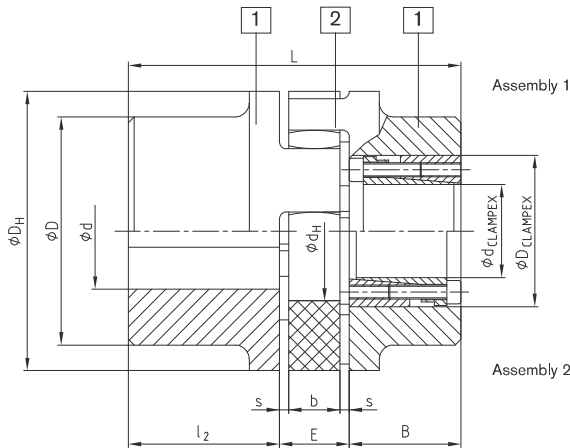

ROTEX® type No. 001 with clamping set CLAMPEX® KTR 200														
Size	ϕd ϕD ϕD_1	Hub material	CLAMPEX® KTR 200			Dimensions [mm]								
			Largest poss KTR clamping set dxD	Transmittable torques and force		B	l ₂	E	s	b	D _H	D	d _H	L
T [Nm]	F _{AX} [kN]													
42			30x55	769	51	48	50	26	3,0	20	95	—	46	
48			35x60	1197	68	48	56	28	3,5	21	105	—	51	
55		Steel part 1	45x75	2132	95	59	65	30	4,0	22	120	—	60	
65			45x75	2132	95	59	75	35	4,5	26	135	115	68	
75			50x80	3159	126	59	85	40	5,0	30	160	135	80	
90			65x95	4107	126	59	100	45	5,5	34	200	160	100	
100			65x95	4107	126	59	110	50	6,0	38	225	180	113	
110		EN-GJS-400-15 part 1	70x110	7023	201	70	120	55	6,5	42	255	200	127	
125			80x120	8026	201	70	140	60	7,0	46	290	230	147	
140			95x135	11373	239	70	155	65	7,5	50	320	255	165	
160			110x155	16068	292	80	175	75	9,0	57	370	290	190	
180			120x165	21910	365	80	195	85	10,5	64	420	325	220	

ROTEX® type No. 001 with clamping set CLAMPEX® KTR 200																	
KTR 200 Size	Length	Transmittable torque and axial force		Clamping screw DIN EN ISO 4762 – 12.9		KTR 200 Size	Length	Transmittable torque and axial force		Clamping screw DIN EN ISO 4762 – 12.9		KTR 200 Size	Length	Transmittable torque and axial force		Clamping screw DIN EN ISO 4762 – 12.9	
		T [Nm]	F _{ax} [kN]	zxM	T _A [Nm]			T [Nm]	F _{ax} [kN]	zxM	T _A [Nm]			T [Nm]	F _{ax} [kN]	zxM	T _A [Nm]
20x47	48	513	51	6xM6	17	38x65	48	1299	68	8xM6	17	65x95	59	4107	126	8xM8	41
22x47	48	564	51	6xM6	17	40x65	48	1368	68	8xM6	17	70x110	70	7023	201	8xM10	83
24x50	48	616	51	6xM6	17	42x75	59	1990	95	6xM8	41	75x115	70	7524	201	8xM10	83
25x50	48	641	51	6xM6	17	45x75	59	2132	95	6xM8	41	80x120	70	8026	201	8xM10	83
28x50	48	718	51	6xM6	17	48x80	59	3033	126	8xM8	41	85x125	70	10659	251	10xM10	83
30x55	48	769	51	6xM6	17	50x80	59	3159	126	8xM8	41	90x130	70	11286	251	10xM10	83
32x60	48	1094	68	8xM6	17	55x85	59	3475	126	8xM8	41	95x135	66	11373	239	10xM10	83
35x60	48	1197	68	8xM6	17	60x90	59	3791	126	8xM8	41	for further details please see CLAMPEX® catalogue					

Design 4.2 with CLAMPEX® clamping set KTR 250

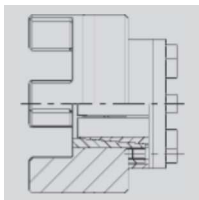

Frictionally engaged, backlash-free shaft-hub-connection for transmission of average torques.

Design 4.3 with CLAMPEX® clamping set KTR 400

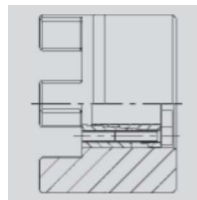

Frictionally engaged, backlash-free shaft-hub-connection for transmission of larger torques. Largest clamping set possible depends on the hub collar diameter. Clamping set screw fitting possible both internally and externally. For details of calculation please see CLAMPEX® catalogue.

Further types with torque limiter

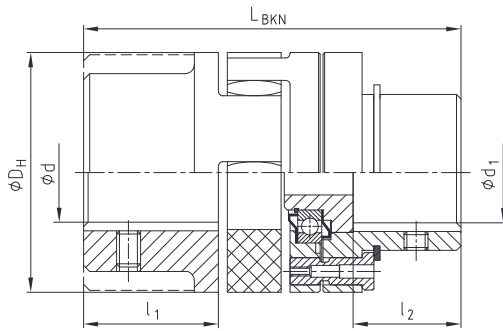

ROTEX® BKN - shear pin coupling, type BKN No. 009							
Size	d	Max. d ₁	l ₁	l ₂	L _{BKN}	D _H	Min. fracture torque [Nm]
28	see shaft coupling on pages 28 and 29 basic programme see pages 26 and 27	28	35	25	101	65	100
38		38	45	35	125	80	190
42		42	50	40	139	95	250
48		48	56	46	153	105	300
55		55	65	55	177	120	400
65		65	75	65	202	135	500
75		75	85	70	230	160	600
90		100	100	85	266	200	700

Modification for customer from the stock programme.
Please mention the fracture torques with your order!
For further details please see dim. sheet no. 5020/000/009-7603

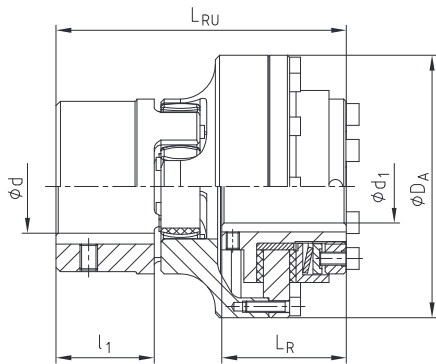

ROTEX® - RUFLEX® - coupling with torque limiter, type No. 070								
ROTEX® Size	RUFLEX® Size	Slipping torques [Nm]	d	d ₁ max.	D _A	l ₁	L _R	L _{RU}
14	00	0,5 – 5	see shaft coupling on pages 28 and 29 basic programme see pages 26 and 27	10	44	11	31	59
19	0	2 – 20		20 ¹⁾	63	25	33	78
24	01	5 – 70		22	80	30	45	98
28	1	20 – 200		25	98	35	52	113
38	2	25 – 400		35	120	45	57	133
48	3	50 – 800		45	162	56	68	166
75	4	90 – 1600		55	185	85	78	205

¹⁾ Finish bore exceeding ø 19, keyway according to 6885 sheet 3

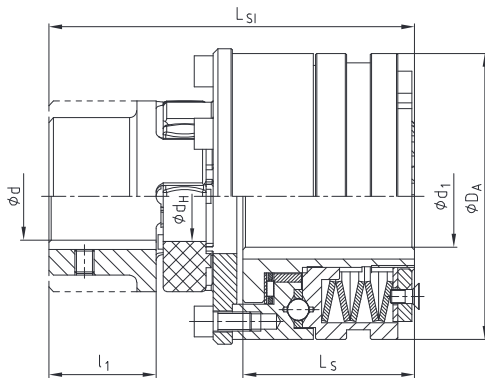

ROTEX® - KTR-SI - coupling with torque limiter, type No. 070									
ROTEX® Size	KTR-SI design	KTR-SI Size	Ratchet torque [Nm]	d	max. d ₁	D _A	l ₁	L _S	L _{SI}
28	DK	2	12-200	see shaft coupling on pages 28 and 29 basic programme see pages 26 and 27	35	100	35	56	124
	SR/SGR	0	5-40		20	55		34,5	102
38	DK	3	25-450		45	120	45	73	155
	SR/SGR	1	12-100		25	82		48	129,5
48	DK	4	50-1000		55	146	56	93,5	194
	SR/SGR	2	25-200		35	100		56	155
55	DK	5	85-2000		65	176	65	107	222,5
	SR/SGR	3	50-450		45	120		73	186
75	DK	—	—		—	—	85	—	—
	SR/SGR	4	100-2000	55	146	93,5		241,5	
90	DK	—	—	—	—	100	—	—	
	SR/SGR	5	170-3400	65	176		107	275,5	

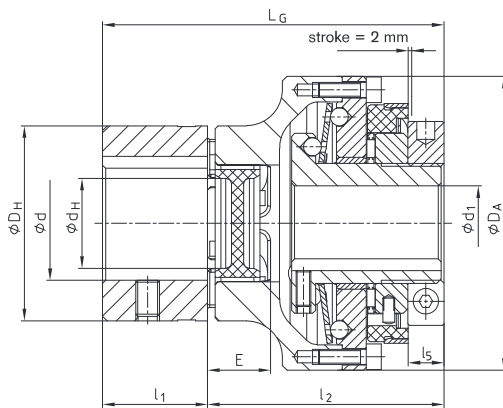

SYNTAX® - backlash-free, torsionally rigid overload coupling with ROTEX® G5																
ROTEX® Size	SYNTAX® Size	SYNTAX® torque range disk spring [Nm]				Max. bore		D _A	D _H	d _H	E	L	L _G	l ₁	l ₂	l ₅
		DK ₁	DK ₂	SK ₁	SK ₂	d	d ₁									
24	20	6-20	15-30	10-20	20-65	35	20	80	55	27	18	45	100	30	70	10
28	25	20-60	45-90	25-65	40-100	40	25	98	65	30	20	50	113	35	78	11
38	35	25-80	75-150	30-100	70-180	48	35	120	80	38	24	60	136	45	91	13
48	50	60-180	175-300	80-280	160-400	55	50	162	105	51	28	70	167	56	111	14

Hub designs

Due to the numerous applications of ROTEX® for many different mounting situations, this coupling system is available with various hub designs. These designs mainly differ in that they offer either positive or frictionally engaged connections, but mounting situations like, for example, gear shafts with integrated transmission cams or similar applications are covered, too.

Design 1.0 hub with keyway and fixing screw

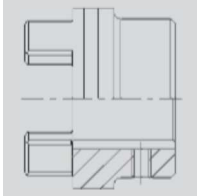

Positive power transmission; permissible torque depends on the permissible surface pressure. Not suitable for backlash-free power transmission for heavily reversing operation.

Design 1.1 hub without feather key, with setscrew

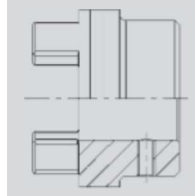

Positive torque transmission for connections pressed or glued in. (No ATEX release)

Design 1.3 hub with spline bore (page 26)

Design 2.0 clamping hub, single slotted, without keyway

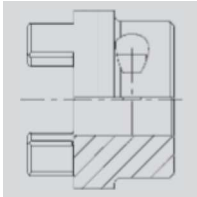

Frictionally engaged, backlash-free shaft-hub-connection. Transmittable torques depend on the bore diameter (page 32). (Only for ATEX category 3)

Design 2.1 clamping hub, single slotted, with keyway

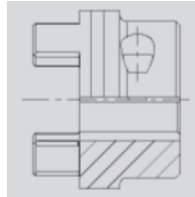

Positive power transmission with additional frictional tightness. The frictional tightness avoids or reduces reversal backlash. Surface pressure of the keyway connection is reduced.

Design 2.3 clamping hub with spline bore (page 26/32)

Design 4.2 with CLAMPEX® clamping set KTR 250

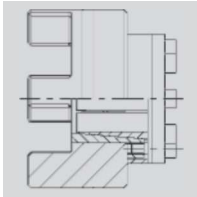

Frictionally engaged, backlash-free shaft-hub-connection for transmission of average torques.

Design 4.1 w. CLAMPEX® clamping set KTR 200/f. KTR 400 design 4.3

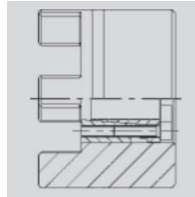

Frictionally engaged, backlash-free shaft-hub-connection for transmission of larger torques. Largest clamping set possible depends on the hub collar diameter. Clamping set screw fitting possible both internally and externally. For details of calculation please see CLAMPEX® catalogue.

Design 6.0 clamping ring hub (see ROTEX® GS series)

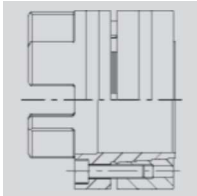

Integrated frictionally engaged shaft-hub-connection for transmission of higher torques. Screw fitting on elastomer side. For details about torques and dimensions see on page 31. Suitable for high speeds.

Design 6.5 clamping ring hub

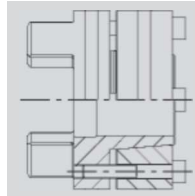

Design equal to 6.0, but clamping screws to be fitted externally. Suitable, for example, for disassembly of radial spacer tubes (special design).

Design 7.5 shell clamping hub without feather key for a double-cardanic connection

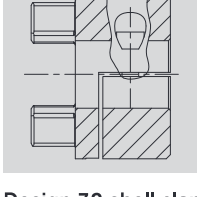

Frictionally engaged, backlash-free shaft-hub-connection for radial assembly of couplings. Transmittable torques depending on the bore diameter. (Only for ATEX category 3)

Design 7.6 shell clamping hub with feather key for a double-cardanic connection

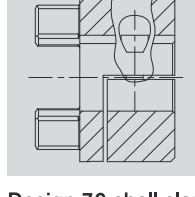

Positive power transmission with additional frictionally engaged operation for radial assembly of couplings. The frictionally engaged operation prevents or reduces reversing backlash, respectively. Surface pressure of the feather key connection is reduced.

Design 7.8 shell clamping hub without feather key

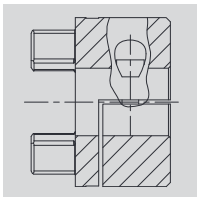

Frictionally engaged, backlash-free shaft-hub-connection for radial assembly of couplings. Transmittable torques depending on the bore diameter. (Only for ATEX category 3)

Design 7.9 shell clamping hub with feather key

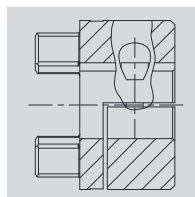

Positive power transmission with additional positive locking for radial assembly of couplings. Positive locking prevents or reduces reversing backlash, respectively. Surface pressure of the feather key connection is reduced.

Special hubs on request

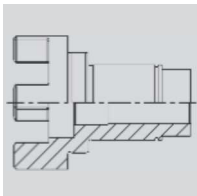

Special lengthened hub/shaft with integrated cams.

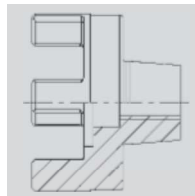

Special hub with external taper as a frictionally engaged connection.

Weights and mass moment of inertia

Components

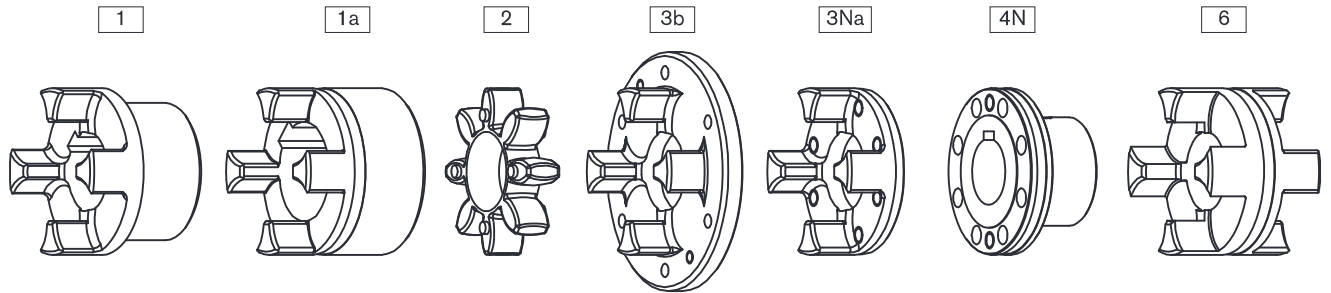

ROTEX® components													
Size	Standard hub				Large hub			Spider	Driving flange			Coupling flange	DKM spacer
	Part 1				Part 1a			Part 2	Part 3b	Part 3Na		Part 4N	Part 6
	Alu [kg] [kgm²]	EN-GJL-250 [kg] [kgm²]	EN-GJS-400-15 [kg] [kgm²]	St [kg] [kgm²]	Alu [kg] [kgm²]	EN-GJL-250 [kg] [kgm²]	St [kg] [kgm²]	Polyurethan (Vulkollan) [kg] [kgm²]	EN-GJS-400-15 [kg] [kgm²]	St [kg] [kgm²]	EN-GJS-400-15 [kg] [kgm²]	St [kg] [kgm²]	Alu [kg] [kgm²]
14	—	—	—	—	0,020	—	—	0,0044	—	—	—	—	—
	—	—	—	—	0,000003	—	—	0,0000005	—	—	—	—	—
19	0,064	—	—	—	0,074	—	0,25	0,0056	—	—	—	—	—
	0,00001	—	—	—	0,00002	—	0,00006	0,00001	—	—	—	—	—
24	0,123	—	—	—	0,174	—	0,55	0,014	0,028	0,145	—	0,30	0,14
	0,00004	—	—	—	0,00008	—	0,00023	0,000006	0,00023	0,00007	—	0,00009	0,00006
28	0,200	—	—	—	0,264	—	0,89	0,024	0,54	0,232	—	0,49	0,22
	0,00010	—	—	—	0,00019	—	0,00053	0,000010	0,0007	0,00017	—	0,0002	0,00013
38	0,44	1,16	—	1,6	0,470	1,32	1,74	0,042	0,73	—	0,313	0,87	0,35
	0,00033	0,00086	—	0,00151	0,00046	0,00135	0,00155	0,00003	0,001	—	0,00038	0,0005	0,00035
42	0,69	1,75	—	2,44	0,772	2,05	2,74	0,065	1,26	—	0,608	1,4	0,47
	0,00067	0,00178	—	0,00281	0,00111	0,00291	0,00343	0,00007	0,0032	—	0,00089	0,0011	0,00068
48	0,80	2,44	—	3,34	1,01	2,78	3,72	0,086	1,45	—	0,755	1,92	0,62
	0,011	0,00308	—	0,00473	0,00174	0,00484	0,00570	0,00013	0,0043	—	0,001358	0,0018	0,0011
55	—	3,68	—	5,05	—	4,08	5,57	0,11	2,58	—	1,243	2,93	0,90
	—	0,00615	—	0,00948	—	0,00926	0,01193	0,00023	0,0105	—	0,002920	0,0037	0,0021
65	—	5,67	—	6,79	—	6,04	8,22	0,17	3,10	—	1,635	4,36	1,31
	—	0,01240	—	0,01516	—	0,01789	0,02079	0,00042	0,0149	—	0,004891	0,0069	0,0039
75	—	8,72	—	10,5	—	9,53	14,3	0,32	4,46	—	2,511	6,80	1,97
	—	0,02644	—	0,03269	—	0,03946	0,05069	0,00116	0,0281	—	0,01050	0,0151	0,0082
90	—	14,8	—	18,7	—	18,2	24,0	0,57	6,94	—	4,151	12,84	3,45
	—	0,06730	—	0,08742	—	0,15086	0,13151	0,00323	0,0651	—	0,02723	0,0448	0,0224
100	—	—	19,7	—	—	—	—	0,81	10,2	—	6,350	16,16	—
	—	—	0,11694	—	—	—	—	0,00588	0,1165	—	0,05273	0,0798	—
110	—	—	27,4	—	—	—	—	1,19	—	—	8,578	21,35	—
	—	—	0,20465	—	—	—	—	0,01097	—	—	0,09121	0,2824	—
125	—	—	42,3	—	—	—	—	1,63	—	—	12,598	34,33	—
	—	—	0,40727	—	—	—	—	0,01972	—	—	0,17469	0,3229	—
140	—	—	58,1	—	—	—	—	2,11	—	—	17,271	48,69	—
	—	—	0,67739	—	—	—	—	0,03129	—	—	0,29247	0,4917	—
160	—	—	84,2	—	—	—	—	3,21	—	—	26,305	71,08	—
	—	—	1,31729	—	—	—	—	0,63228	—	—	0,59436	0,9693	—
180	—	—	118,5	—	—	—	—	5,25	—	—	33,076	109,43	—
	—	—	2,30835	—	—	—	—	0,13789	—	—	0,97394	1,9650	—

Weight and mass moment of inertia each refer to the medial finish bore without keyway.

Weights and mass moment of inertia

ROTEX® complete couplings												
Size	AFN		BFN		CF		DF		ZWN ¹⁾		SD	
	Weight [kg]	Mass moment of inertia J [kgm ²]	Weight [kg]	Mass moment of inertia J [kgm ²]	Weight [kg]	Mass moment of inertia J [kgm ²]	Weight [kg]	Mass moment of inertia J [kgm ²]	Weight [kg]	Mass moment of inertia J [kgm ²]	Weight [kg]	Mass moment of inertia J [kgm ²]
19	—	—	—	—	0,44	0,00016	0,38	0,00020	—	—	0,42	0,00008
24	0,98	0,00036	1,1	0,00041	0,84	0,00047	0,57	0,00047	2,2	0,00084	1,1	0,00046
28	1,6	0,00083	1,7	0,00095	1,5	0,00124	1,1	0,00141	3,6	0,00193	1,9	0,00106
38	2,8	0,00209	2,6	0,00193	1,9	0,00217	1,5	0,00259	5,5	0,00393	3,0	0,00435
42	4,5	0,00472	4,1	0,00419	3,1	0,00513	2,6	0,00662	8,6	0,00853	4,4	0,00804
48	5,9	0,00736	5,5	0,00684	3,9	0,00755	3,0	0,00881	11,3	0,0138	6,2	0,00223
55	8,9	0,01480	8,3	0,01369	6,4	0,01692	5,3	0,02131	17,7	0,0279	9,8	0,0166
65	12,9	0,0266	12,3	0,0259	8,9	0,02780	6,4	0,003037	26,3	0,0531	14,9	0,0326
75	20,6	0,0601	19,3	0,0572	13,5	0,0557	9,2	0,05741	41,6	0,1172	23,2	0,0706
90	37,8	0,1718	34,2	0,1551	22,3	0,1356	14,5	0,1333	73,2	0,3173	40,5	0,1891
100	49,6	0,3068	45,2	0,2737	30,9	0,2401	21,2	0,2394	98,7	0,5629	46,7	0,2467
110	67,5	0,5385	61,7	0,4793	42,9	0,4324	29,8	0,4446	135,1	0,986	61,5	0,4186
125	102,6	1,0485	94,4	0,9413	64,4	0,8187	42,2	0,8031	206,2	1,937	96,8	0,8497
140	141,2	1,743	129,7	1,564	90,4	1,4221	62,5	1,4580	283,3	3,222	127,8	1,368
160	210,3	3,517	190,9	3,107	127,6	2,589	83,6	2,4805	418,2	6,393	190,3	2,723
180	306,6	6,582	274,4	5,668	175,1	4,448	107,9	4,141	601,9	11,682	262,2	4,810

BTAN/SBAN without drum/disk		
Size	Weight [kg]	Mass moment of inertia J [kgm ²]
28	0,90	0,0004
38	2,10	0,0014
42	3,24	0,0031
48	4,41	0,0053
55	6,60	0,0105
65	10,1	0,0209
75	15,4	0,0442
90	27,6	0,1224
100	36,9	0,2074
110	50,9	0,3665
125	79,1	0,7349
140	109,0	1,2292
160	161,9	2,4569
180	232,9	4,4967

Drum for BTAN ²⁾		
Brake disk ∅D _B x B	Weight [kg]	Mass moment of inertia J [kgm ²]
160 x 60	2,12	0,01
200 x 75	3,45	0,03
250 x 95	6,87	0,08
315 x 118	14,95	0,28
400 x 150	31,20	0,89
500 x 190	60,00	2,70
630 x 236	112,00	8,01
710 x 265	161,00	14,9
800 x 300	202,00	27,2

Disk for SBAN ²⁾		
Disk brake ∅A x G _S	Weight [kg]	Mass moment of inertia J [kgm ²]
200 x 12,5	2,928	0,015367
250 x 12,5	4,662	0,037584
315 x 16	8,618	0,111829
400 x 16	15,230	0,315206
500 x 16	23,964	0,769963
630 x 20	47,716	2,426359
710 x 20	60,934	3,915100
800 x 25	94,913	7,878998
900 x 25	118,954	12,609089
1000 x 25	148,240	19,234941

Weights and mass moments of inertia refer to standard hub with medial bore without keyway.

¹⁾ Weights and mass moments of inertia without intermediate shaft.

²⁾ Selection of ROTEX® brake drum - disk brake please see page 39.

